

Design of an Almost Harmonic-free TCR

Abdulkareem Mokif Obais and Jagadeesh Pasupuleti

Department of Electrical Power Engineering, Universiti Tenaga Nasional, Malaysia

Abstract: In this study, the traditional thyristor controlled reactor is conditioned to be an almost harmonic-free inductive static Var compensator. The proposed configuration is constructed of a traditional TCR shunted by a parallel resonance circuit and the parallel combination is connected in series to a series resonance circuit. The parallel and series resonance circuits are tuned at the power system fundamental frequency. The series resonance circuit offers almost short circuit to the AC source current fundamental, while it offers very high impedance to the harmonic current components released by the TCR. The parallel resonance circuit offers very high impedance to the AC source current fundamental, while it offers almost short circuits to the harmonic current components released by the TCR. The two circuits operate coherently such that negligible current harmonics are permitted to flow in the AC source side. This type of harmonic treatment is not sensitive to other harmonic sources in the power system network, where this compensator is installed. The no load operating losses of this compensator are negligible compared to its reactive power rating. The proposed compensator is designed and tested on PSpice.

Keywords: Controlled reactors, power quality, reactive power control, TCR

INTRODUCTION

Static Var compensators are very essential in reactive power control applications for power quality improvement purposes. Both absorption and generation of reactive power are required for voltage control, load balancing and automatic power factor correction techniques (Gyugyi, 1988; Paziuk *et al.*, 1989; Moran *et al.*, 1993; Chen *et al.*, 1999; Lee and Wu, 2000; Valderrama *et al.*, 2001; Xu *et al.*, 2010). Synchronous condensers can be used in applications requiring balanced control of reactive power in both modes of operation (capacitive and inductive), but they are characterized by slow responses, high operating losses and high installation and operating costs compared with static Var compensators (Teleke *et al.*, 2008). Static Var compensators that offer continuous control of reactive power absorption are either conventional thyristor-controlled reactors (Gyugyi, 1988; Paziuk *et al.*, 1989; Chen *et al.*, 1999; Lee and Wu, 2000; Xu *et al.*, 2010), or STATCOMS (Moran *et al.*, 1993; Valderrama *et al.*, 2001). Both compensators release noticeable current harmonics, but the TCR can operate at higher voltage and current ratings (Best and Zelaya-De La Parra, 1996; Jalali *et al.*, 1996; IEEE, PES Harmonic Working Group, 2001). The TCR releases in the power system network significant odd harmonics, which have undesirable effects such as extra losses, over currents, voltage fluctuations and noises to telecommunication systems. TCR harmonics are

usually eliminated by using passive or active filters (Gyugyi, 1988; Lee and Wu, 2000). The design of these filters depends on the AC short circuit level at the location where the TCR should be installed (IEEE, PES Harmonic Working Group, 2001). Consequently, these filters will dissipate a lot of losses and generate large amounts of undesirable reactive power at the AC supply fundamental. In addition, these filters are vulnerable to the effects of other sources of harmonics in the AC network, thus they may become less efficient. Many techniques were presented to treat TCR harmonics without using harmonic filters such as using sequential control of transformer taps and asymmetrical firing to a TCR to minimize certain harmonics, but both techniques have limited outcomes (Patel and Dubey, 1983; Funabiki and Himei, 1985).

In this study, many of the drawbacks of optimal performance associating the above filtering techniques are treated by presenting a compact inductive static Var compensator constructed of a traditional TCR shunted by a parallel resonance tuned circuit and the parallel combination is connected in series to a series resonance tuned circuit. Both circuits resonate at the AC supply fundamental frequency.

The traditional TCR: The traditional TCR and its current waveform are shown in Fig. 1. Its current i_X is not sinusoidal, but symmetrical around ωt axis, thus it only contains odd harmonic components.

The fundamental I_1 and the n th harmonic I_n of i_X are given by (Gyugyi, 1988):

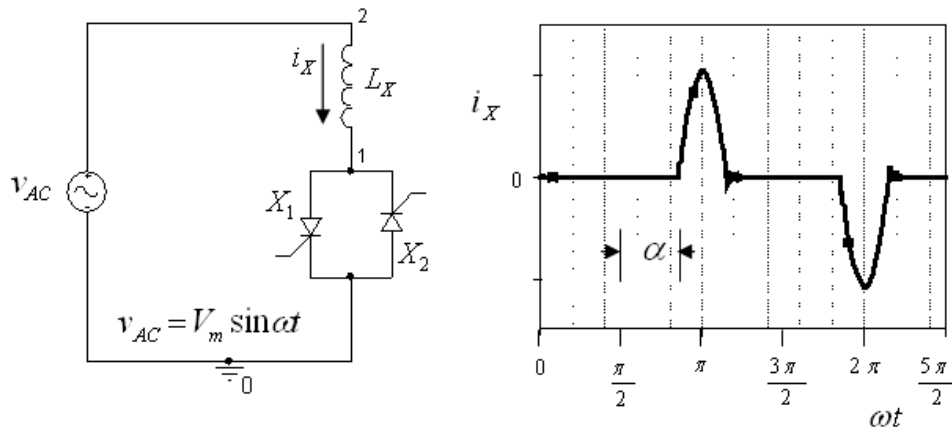

Fig. 1: The traditional TCR and its current waveform

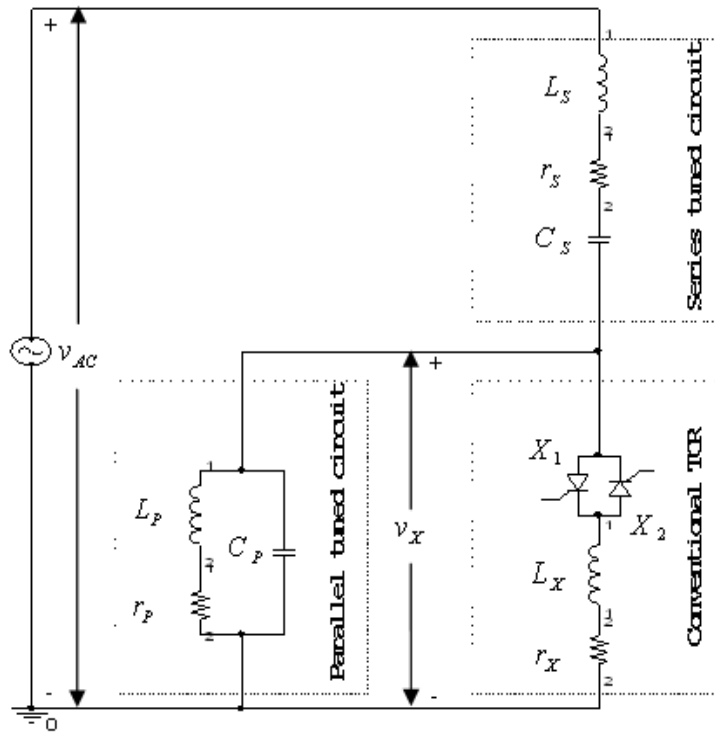

Fig. 2: The proposed almost harmonic-free TCR

$$I_1 = \frac{V_m}{\omega L_X} \left(1 - \frac{2}{\pi} \alpha - \frac{1}{\pi} \sin 2\alpha \right) \quad (1)$$

$$I_n = \frac{4V_m}{\pi \omega L_X} \left(\frac{\sin \alpha \cos(n\alpha) - n \cos \alpha \sin(n\alpha)}{n(n^2 - 1)} \right) \quad (2)$$

$$= \frac{V_n}{n \omega L_X}$$

L_X = The self inductance of its reactor
 n = A positive odd integer greater than unity (i.e., $n = 3, 5, 7, \dots$)

V_n = Defined by:

$$V_n = \frac{4V_m}{\pi} \left(\frac{\sin \alpha \cos(n\alpha) - n \cos \alpha \sin(n\alpha)}{(n^2 - 1)} \right) \quad (3)$$

where,

V_m = The voltage amplitude of the AC supply

ω = Angular frequency of the AC supply

α = The TCR firing angle

The TCR firing angle α varies in the range of $0 \leq \alpha \leq \pi/2$. When the firing angle of the TCR is zero, the maximum fundamental current I_{MAX} absorbed by the TCR according to Eq. (1) is given by:

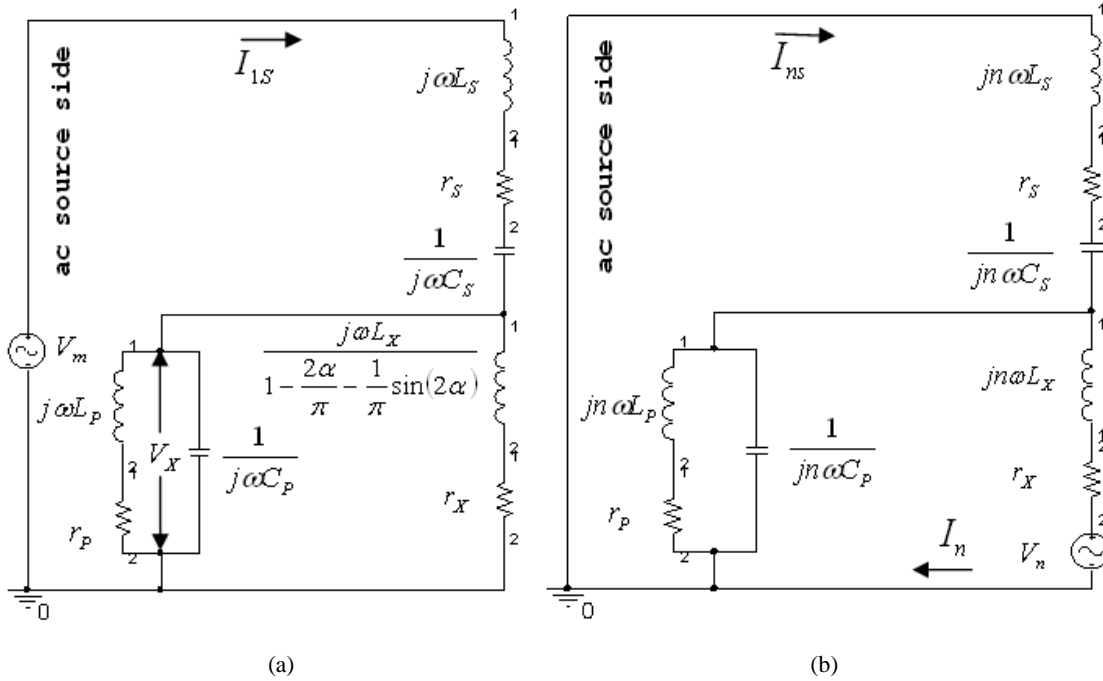

Fig. 3: Modeling of the proposed compensator at: (a) fundamental frequency, (b) nth harmonic

$$I_{MAX} = \frac{V_m}{\omega L_X} \quad (4)$$

$$V_x = V_m - r_s I_{1s} \cong V_m, \text{ if } r_s I_{1s} \ll V_m \quad (7)$$

The proposed almost harmonic-free TCR: The proposed compensator is constructed of a traditional TCR equipped with parallel and series tuned circuits as shown in Fig. 2.

Both tuned circuits resonate at the fundamental angular frequency ω of the power system network feeding the TCR. The series tuned circuit offers high impedances to the odd harmonics released by the TCR, while the parallel tuned circuit offers almost short circuits to them. If the above objectives are approached, then it can be said to some extent that the proposed system is harmonic-free and the voltage across the TCR v_x and the AC input voltage v_{AC} are approximately equal in magnitude and phase. The fundamental and the nth harmonic equivalent circuits of the proposed inductive static Var compensator are shown in Fig. 3. In this figure, the TCR is modeled according to Eq. (1) and (2). Since both series and parallel tuned circuits are designed to resonate at the fundamental frequency of the AC source, then the following can be written:

$$Z_s(\omega) = j\omega L_s + \frac{1}{j\omega C_s} + r_s = r_s \quad (5)$$

$$Z_p(\omega) = (j\omega L_p + r_p) // \left(\frac{1}{j\omega C_p} \right) \cong \frac{(\omega L_p)^2}{r_p} \quad (6)$$

where,

- $Z_s(\omega), Z_p(\omega)$ = The impedances of series and parallel tuned circuits at ω
- L_p, r_p = The self inductance and resistance of the parallel resonance reactor
- L_s, r_s = The self inductance and resistance of the series resonance reactor
- I_{1s} = The AC source current fundamental
- r_x = Negligible compared to ωL_x
- I_{1s} = Be closely approximated to:

$$I_{1s} = \frac{V_m}{j\omega L_x} \left(1 - \frac{2\alpha}{\pi} - \frac{1}{\pi} \sin(2\alpha) \right) + \frac{r_p V_m}{(\omega L_p)^2} \quad (8)$$

$$= |I_{1s}| \angle \theta_{1s}$$

where, $|I_{1s}|$ and θ_{1s} are the magnitude and phase of I_{1s} and are given by:

$$|I_{1s}| = \frac{V_m}{\omega L_x} \left| -j \left(1 - \frac{2\alpha}{\pi} - \frac{1}{\pi} \sin(2\alpha) \right) + \frac{r_p L_x}{\omega L_p^2} \right| \quad (9)$$

$$\theta_{1s} = \tan^{-1} \left(- \frac{\omega L_p^2}{r_p L_x} \left(1 - \frac{2\alpha}{\pi} - \frac{1}{\pi} \sin(2\alpha) \right) \right) \quad (10)$$

At frequencies above fundamental, the self-resistances of the tuned circuit's reactors become

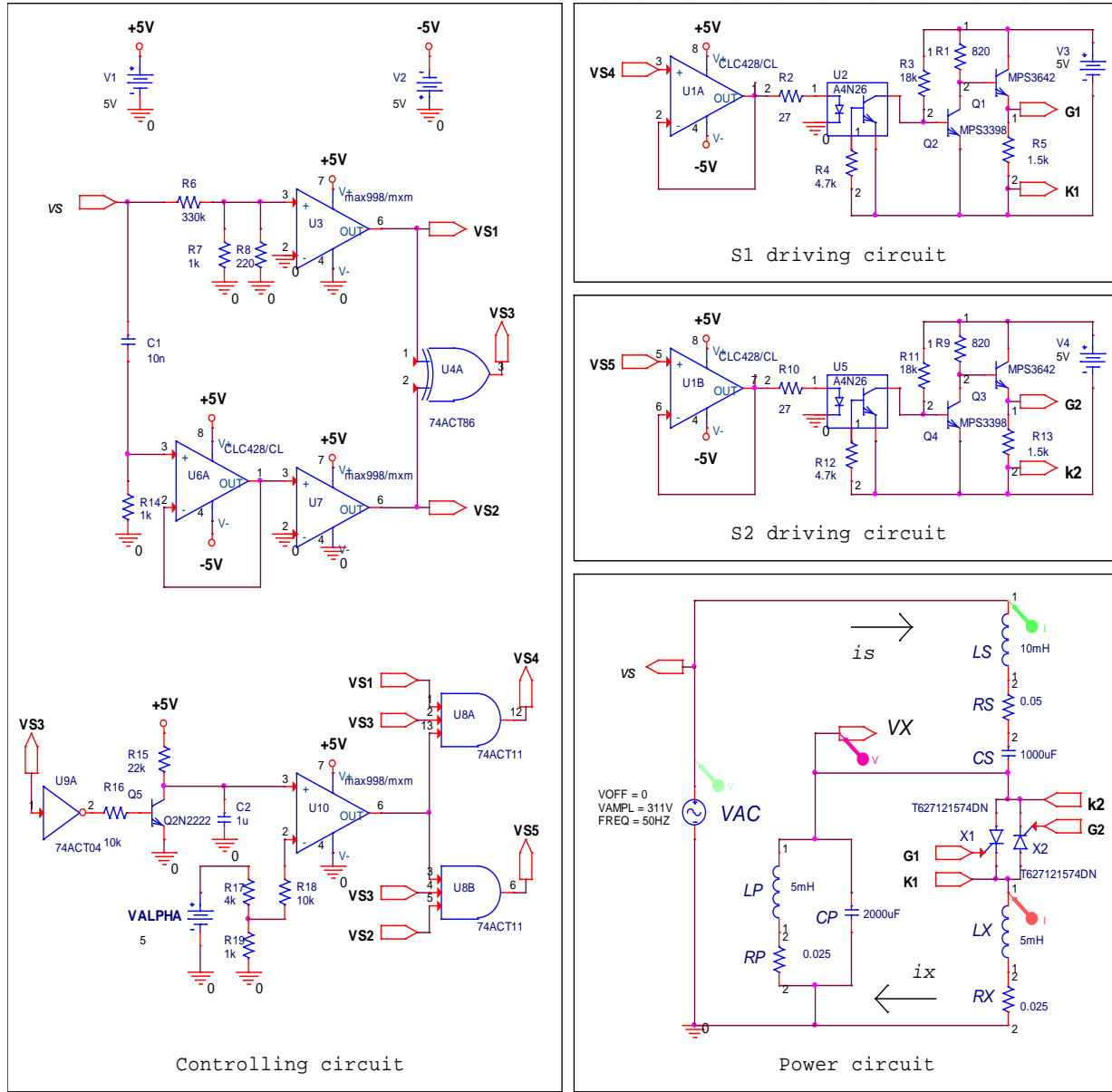

Fig. 4: The PSpice demonstration system of the almost harmonic-free TCR

ineffective, thus the n th harmonic current I_{ns} flowing in the AC source side can be given by:

$$I_{ns} = I_n \frac{Z_p(n\omega)}{Z_p(n\omega) + Z_s(n\omega)} = I_n \frac{\frac{1}{jn\omega C_p + \frac{1}{jn\omega L_p}}}{\frac{1}{jn\omega C_p + \frac{1}{jn\omega L_p}} + jn\omega L_s + \frac{1}{jn\omega C_s}} \quad (11)$$

$$= I_n \frac{\frac{jnX_p}{(1-n^2)}}{\frac{jnX_p}{(1-n^2)} + \frac{jX_s(n^2-1)}{n}}$$

$$= I_n \frac{n^2 X_p}{n^2 X_p - X_s (1-n^2)^2}$$

where, X_p and X_s are the characteristic impedances of the parallel and series resonance circuits at the AC fundamental frequency. They can be expressed as follows:

$$X_p = \omega L_p = \frac{1}{\omega C_p} \quad (12)$$

$$X_s = \omega L_s = \frac{1}{\omega C_s} \quad (13)$$

If X_s and X_p are chosen such that $X_s = 2\omega L_x$ and $X_p = \omega L_x$, then Eq. (11) will be reduced to:

$$I_{ns} = I_n \frac{n^2}{n^2 - 2(1 - n^2)^2} \quad (14)$$

If r_p is negligible compared with X_p , then the compensator fundamental current magnitude $|I_{IS}|$ defined in Eq. (9) will be determined only by the TCR firing angle α and the phase angle θ_{IS} defined by Eq. (10) will be approximated to -90° for all values of α corresponding to noticeable values of $|I_{IS}|$.

PSpice validation system: A demonstration system of the proposed compensator implemented on PSpice is shown in Fig. 4. The controlling circuit of this system is designed such that the TCR firing angle α is varied from 0 to 90° by varying the DC voltage source V_{ALPHA} from 0 to 5V. V_{ALPHA} is directly proportional to reactive power demand. A distribution system of 220V and 50Hz was chosen as the AC supply of the proposed compensator. The TCR reactor was chosen to have an inductance of 5 mH and self resistance of 0.025 Ω .

Accordingly, the reactors of the tuned circuits were designed such that $L_S = 2L_X = 10$ mH, $r_S = 2r_X = 0.05\Omega$, $L_P = L_X = 5$ mH and $r_P = r_X = 0.025\Omega$. Consequently, their capacitors are calculated as follows: $C_P = 2000 \mu\text{F}$ and $C_S = 0.5C_P = 1000 \mu\text{F}$. The AC voltage used in Fig. 4 is of amplitude of 311V (corresponds to an rms value of 220V) and frequency of 50 Hz.

RESULTS AND DISCUSSION

The compensator circuit shown in Fig. 4 was tested on PSpice for $\alpha = 0, 30^\circ, 45^\circ, 60^\circ$ and 90° . At $\alpha = 30^\circ, 45^\circ$ and 60° , the low order odd current harmonics have significant values. The simulation results are shown in Fig. 5 to 9. The PSpice simulation results show that the compensator current is pure sinusoidal and exhibits positive peaks at the negative slope zero crossing points of the AC voltage, thus it is pure inductive current. The frequency spectrums of the compensator current

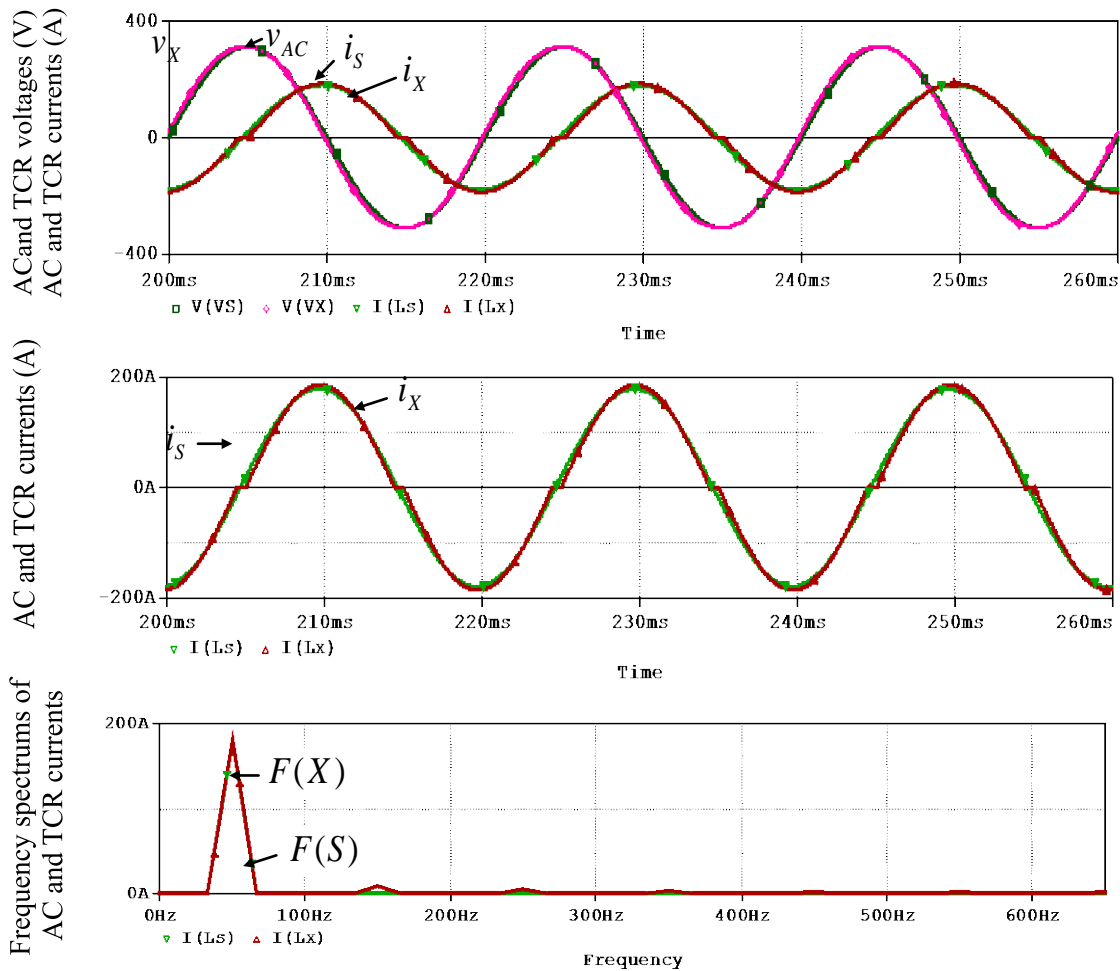

Fig. 5: AC voltage v_{AC} , TCR voltage v_X , compensator current i_s , TCR current i_x , i_s frequency spectrum $F(S)$, and i_x frequency spectrum $F(X)$ at $\alpha = 0$

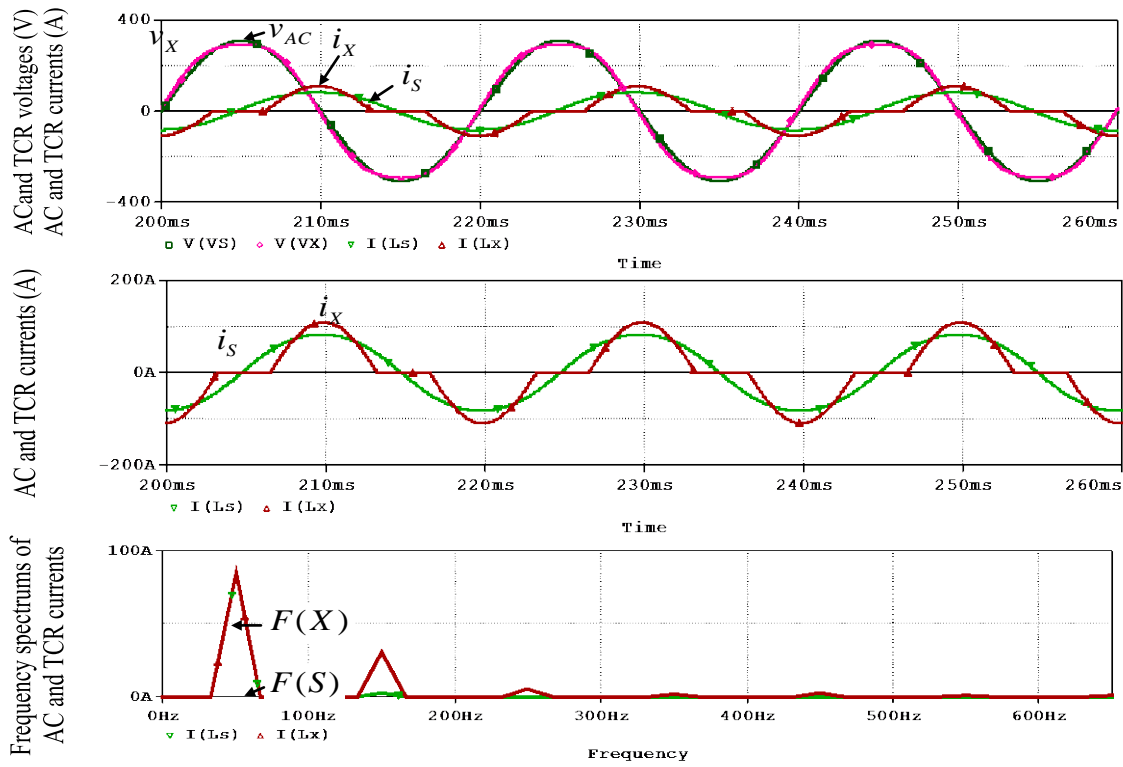

Fig. 6: AC voltage v_{AC} , TCR voltage v_X , compensator current i_S , TCR current i_X , i_S frequency spectrum $F(S)$, and i_X frequency spectrum $F(X)$ at $\alpha = 30^\circ$

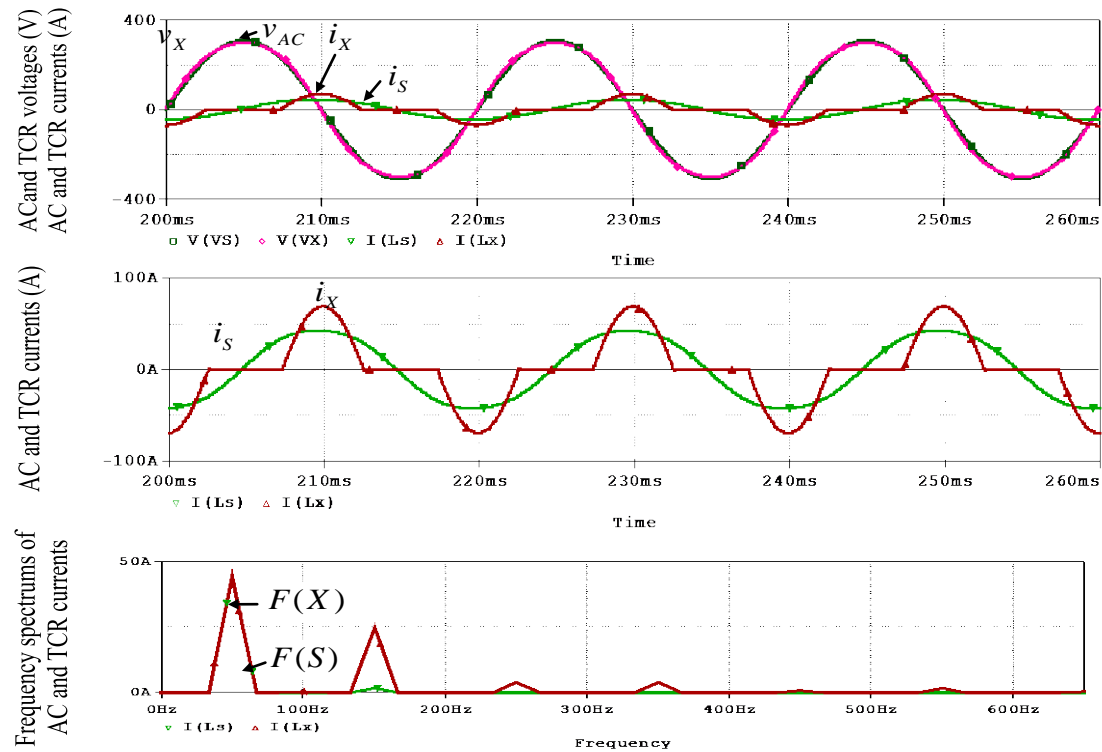

Fig. 7: AC voltage v_{AC} , TCR voltage v_X , compensator current i_S , TCR current i_X , i_S frequency spectrum $F(S)$, and i_X frequency spectrum $F(X)$ at $\alpha = 45^\circ$

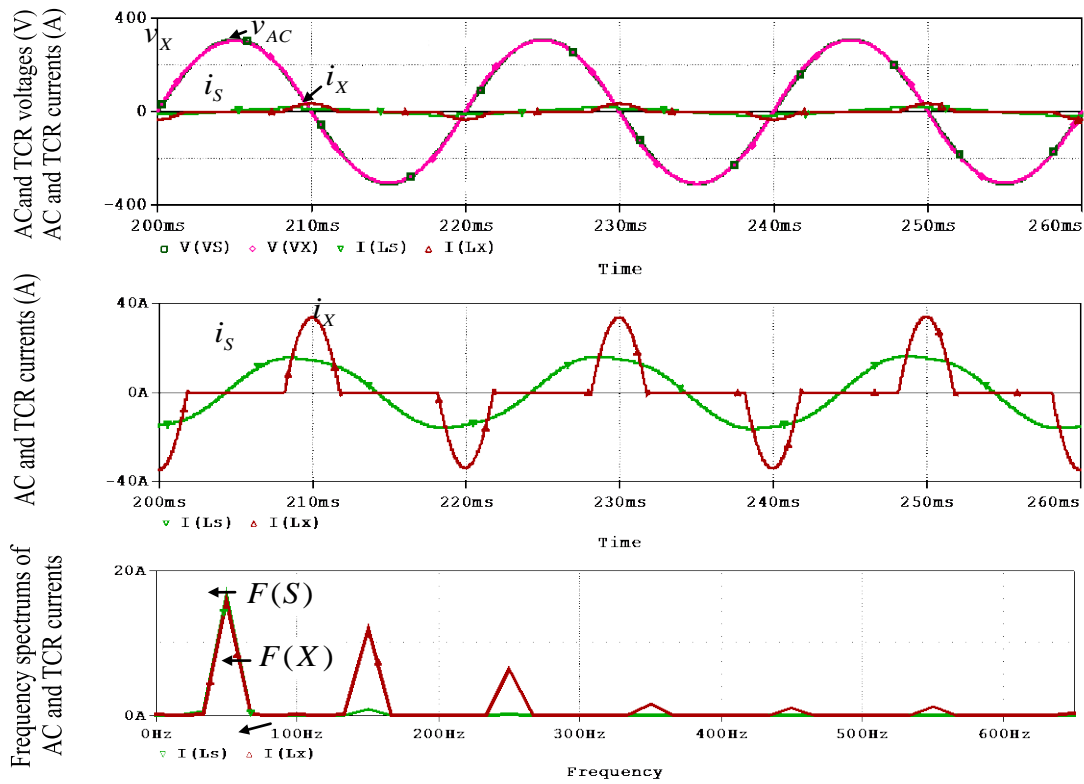

Fig. 8: AC voltage v_{AC} , TCR voltage v_X , compensator current i_S , TCR current i_X , i_S frequency spectrum $F(S)$, and i_X frequency spectrum $F(X)$ at $\alpha = 60^\circ$

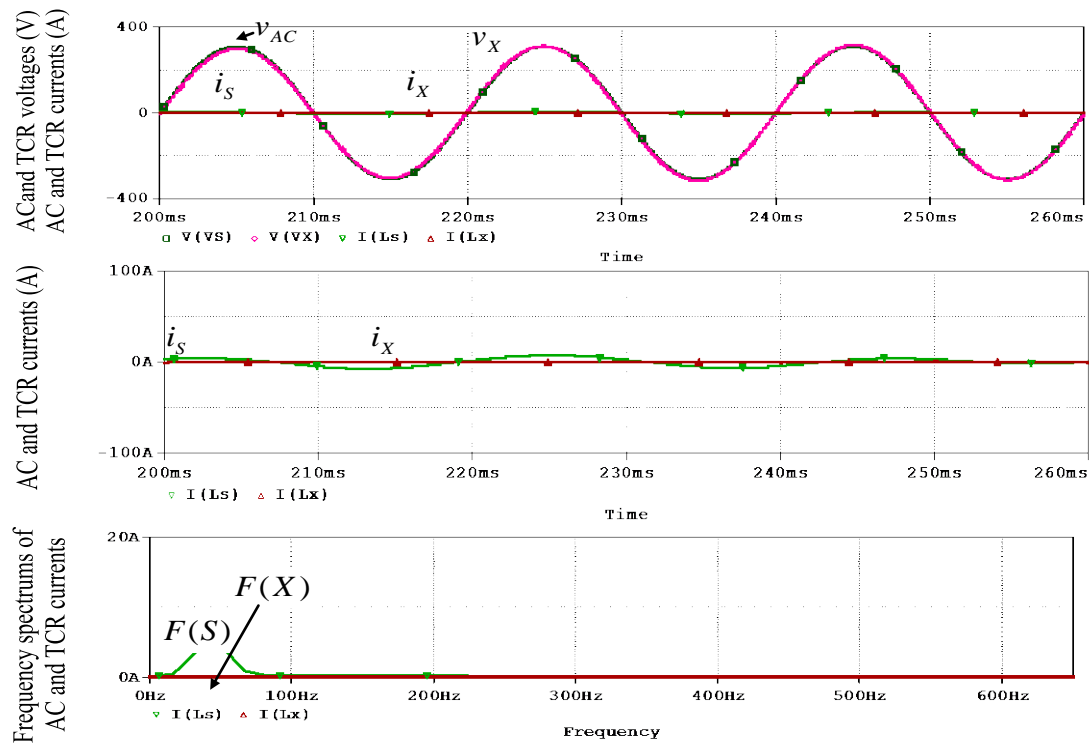

Fig. 9: AC voltage v_{AC} , TCR voltage v_X , compensator current i_S , TCR current i_X , i_S frequency spectrum $F(S)$, and i_X frequency spectrum $F(X)$ at $\alpha = 90^\circ$

F(S) and TCR current F(X) show coincidence of their fundamental components and big reduction in harmonic current components flowing in the AC source side.

CONCLUSION

PSpice simulation results ensure that the third harmonic current components flowing in the AC source side is reduced to about 0.075 the component released by the TCR. This is thoroughly coinciding with the value obtained from Eq. (14) after substituting for n by 3. Consequently, the third harmonic current component flowing in the AC source side will never exceed 1% of the compensator reactive current rating. Other odd harmonic current components suffer much reduction. For instance, the 5th harmonic current component flowing in the AC source side is reduced to 0.022 the component released by the TCR. At $\alpha = 90^\circ$, the compensator draws a resistive current of about 3A (peak value) which only represents about 1.5% of the compensator reactive current rating. Consequently, it can be deduced that the proposed compensator is almost harmonic-free inductive static Var with negligible no load operating losses compared to its reactive current rating. It can be used for all applications requiring reactive power control such as load balancing and voltage regulation. The filtering efficiency of this compensator is not sensitive to other sources of harmonics in its neighborhood in the power system network due to the high harmonics isolation offered by the series resonance circuit. Real power exchanged by this compensator with AC source is somewhat negligible compared with its reactive power rating.

REFERENCES

- Best, R.A and H.Z. Zelaya-De La Parra, 1996. Transient response of a static var shunt compensator. *IEEE T. Power Electron.*, 11(3): 489-494.
- Chen, J.H., W.J. Lee and M.S. Chen, 1999. Using a static var compensator to balance a distribution system. *IEEE T. Ind. Appl.*, 35(2): 298-304.
- Funabiki, S. and T. Himei, 1985. Design procedure of firing angles for harmonic reduction in a thyristor-controlled reactor by asymmetrical firing control. *IEE Proc-C*, 132(5): 257-264.
- Gyugyi, L., 1988. Power electronics in electric utilities: Static Var compensators. *Proc. IEEE*, 76(4): 483-494.
- IEEE, PES Harmonic Working Group, 2001. Characteristics and modeling of harmonic sources-power electronic devices. *IEEE T. Power Deliver.*, 16(4): 791-800.
- Jalali, S., I. Dobson, H.R. Lasseter and G. Venkataraman, 1996. Switching time bifurcations in a thyristor controlled reactor. *IEEE T. Circuits-I*, 43(3): 209-218.
- Lee, S.Y. and C.J. Wu, 2000. Reactive power compensation and load balancing for unbalanced three-phase four-wire system by a combined system of an SVC and a series active filter. *IEE Proc-B*, 147(6): 563-571.
- Moran, L., P.D. Ziogas and G.A. Joos, 1993. Solid-state high-performance reactive power compensator. *IEEE T. Ind. Appl.*, 29(5): 969-978.
- Patel, H.K. and G.K. Dubey, 1983. Harmonic reduction in the static VAR compensator by sequence control of transformer taps. *IEE Proc-C*, 130(6): 300-305.
- Paziuk, L.A., A.Y. Chikhani and R. Hackam, 1989. An expert microprocessor voltage regulator for energy observation and demand reduction in distribution feeders. *IEEE T. Power Deliver.*, 4: 2222-2228.
- Teleke, S., T. Abdulahovic, T. Thiringer and J. Svensson, 2008. Dynamic performance comparison of synchronous condenser and SVC. *IEEE T. Power Deliver.*, 23(3): 1606-1612.
- Valderrama, G.E., P. Mattavelli and A.M. Stankovic, 2001. Reactive power and unbalance compensation using STATCOM with dissipativity-based control. *IEEE T. Contr. Syst. T.*, 9(5): 718-727.
- Xu, Y., L.M. Robert, J.D. Kueck and D.T. Rizy, 2010. Voltage and current unbalance compensation using a static var compensator. *IET Power Electron.*, 3(6): 977-988.