

Enhancing the Punching Behavior of High Strength Concrete Flat Plates Subjected to Repeated Load by Using Shear Reinforcement

Nameer Abdalameer Alwash

University of Babylon/College of Engineering
nameeralwash@yahoo.com

Ghalib Mohsin Habeeb

University of Babylon/College of Engineering
Ghalibmohsin@yahoo.com

Hussein Talab Nhabih

University of Babylon/College of Materials Engineering
eng.hussein.t@uobabylon.edu.iq

Abstract

The present study includes an experimental and numerical investigations for the punching behavior of shear reinforced square simply supported flat plates of high strength concrete (HSC) subjected to repeated load. The experimental program consists of testing four flat plate models. They were of the same overall dimensions of plate, (900×900×100) mm and dimensions of column (150×150×300) mm. The main variable has been considered in the experimental study is: type of shear reinforcement (three models): closed stirrups, headed shear studs and bent bars. Finally, a fourth model (without shear reinforced) served as control model. From the results of this work, It was found that the closed stirrups is the best type of shear reinforcement because this type is highly increase punching shear strength (about 92%) , rotation capacity, simple and cost-effective. Three-dimensional nonlinear finite element analysis has been carried out to conduct the numerical investigation of the general behavior of HSC flat plat models. ABAQUS (Version 6, copyright 2013) computer program was used in this work. A comparison between numerical and experimental results showed good validity of the numerical analysis where the average difference ratio based on the ultimate load was less than 3.67% for all analyzed models.

Keywords: Flat Plates, Punching Behavior, Shear Reinforcement, High Strength Concrete, Repeated Load, Finite Element.

الخلاصة

تتضمن الدراسة الحالية التحري العملي والتحليلي لسلوك الثقب لتسليح القص السقوف المستوية مربعة الشكل والمسندة بإسناد بسيط والمصبوبة باستخدام خرسانة عالية المقاومة و المعرضة لحمل تكراري. يتألف البرنامج العملي من فحص اربع نموذج سقوف مستوية بنفس الأبعاد الكلية لجميع السقوف (100×900×900) ملم والأعمدة (300× 150×150) ملم. أهم متغير أخذت بنظر الاعتبار في هذه الدراسة هو نوع تسليح القص (ثلاث نماذج): الاطواق الفولاذية المغلقة، مسامير القص الفولاذية و القضبان الفولاذية المنحنية. اخيرا، النموذج الرابع (بدون حديد تسليح قصي) يعمل كنموذج مرجعي. من نتائج هذا العمل، وجد بأن الاطواق الفولاذية المغلقة افضل انواع تسليح القص لان هذا النوع يعطي زيادة عالية في مقاومه القص الثاقب (حوالي 92%) و استيعابه الدوران، سهل واقتصادي. التحري التحليلي قدم أنموذجا لا خطيا بالاعتماد على عناصر ثلاثية الأبعاد ملائمة لتحليل نماذج السقوف المستوية المصبوبة باستخدام خرسانة عالية المقاومة باستخدام البرنامج الحاسوبي (ABAQUS، الإصدار 6 - النسخة 2013). المقارنة بين النتائج العملية والتحليلية بينت توافق جيد حيث كان معدل نسبة الاختلاف بالاعتماد على الحمل النهائي لا يزيد عن 3.67% لكل النماذج المحللة.

الكلمات المفتاحية: السقوف المستوية، سلوك الثقب، حديد التسليح القصي، خرسانه عالية المقاومة، حمل تكراري، العناصر المحددة.

1. Introduction

An efficient method to increase the strength and the deformation capacity of flat plates is the punching shear reinforcement. Specially, the increase in deformation capacity is desired so that the load can be distributed to other supports avoiding a total failure of the structure in the case of the occurrence of a local failure. Thus, it provides a satisfactory deformation capacity. There are several types of punching shear reinforcement systems see Fig.1:-

a) corrugated double headed shear studs. b) smooth double headed shear studs. c) steel offcuts. d) headed stirrups. e) stirrups with lap at the vertical branch. f) stirrups or shear links. g) continuous stirrups or cages of shear links. h) stirrup and link with hooks at tension face. k) Shear heads. l) bent-up bars. (m) closed stirrups, (Corley and Hawkins, 1968, 1974).

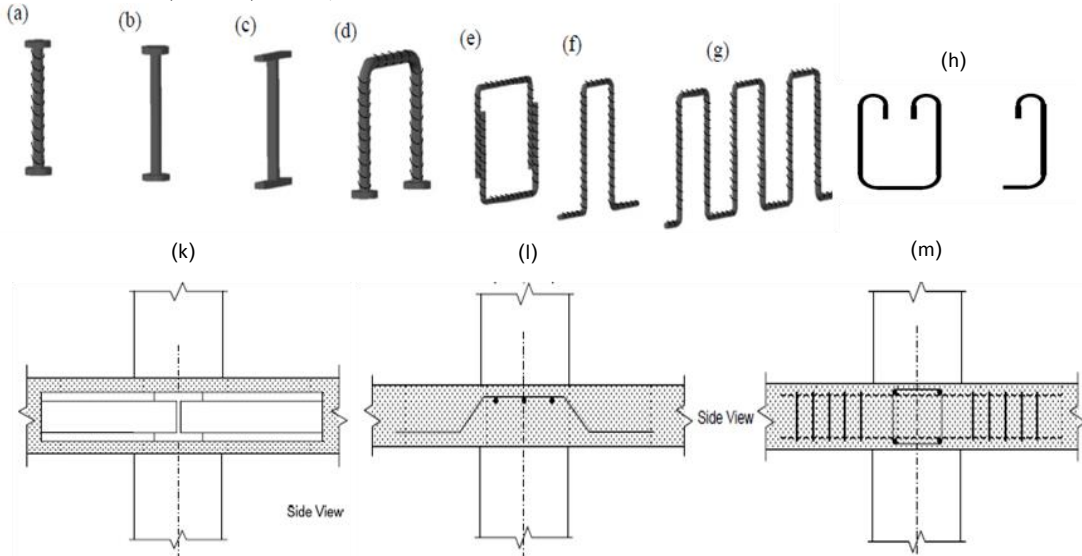

Fig.1:-Examples of punching shear reinforcement systems, (Islam and Park, 1976).

In advent of construction technology the use flat plates are increasing in the building construction. Flat plates are easy to build and have through their smaller depth, an economical and architectural advantages compared to slab with beams. The undesirable suddenness and catastrophic nature of punching failure are of concern to structural engineers (Yogendran et.al., 2007). Thus, it is significant to investigate the efficiency of the use of shear reinforcement to improve the punching shear strength of flat plates under repeated load.

Several research studies reported in the literature on improving the punching behavior of flat plates. Two studies are presented in this section.

Broms, 2000 reported on the monotonic tests of two specimens reinforced by 35-degree bent-up bars in each principal direction. The results showed that bent-up shear reinforcement had limited effect on slab punching shear capacity and ductility.

Robertson et. al., 2002 tested of slab-column connections reinforced with either hoops, single-leg stirrups or shear studs under combined lateral loading and relatively low levels of gravity load. They concluded that these three types of shear reinforcement are equally effective in contributing to punching shear resistance. However, shear stud reinforcement was found to be more practical from a construction viewpoint. There is no available work has been found on the use of shear reinforcement in HSC flat plates under repeated load.

2. Experimental Program

2.1 Details of Test Models

The experimental program of this study consisted of testing four flat plate reinforced concrete square models. All models have same dimensions and

reinforcements; 900×900 mm (overall dimensions), 800 mm (span length), 100 mm (overall depth), 20 mm (clear cover in bottom and sides of slab), 150×150 mm (square column), 300 mm (height of column stubs), 20 mm (clear cover in top and sides of column) as shown in Fig.2.

All flat plate models were reinforced with a high amount of flexural reinforcement ($\rho = 2.24\%$). Also, columns were reinforced with more steel ($\rho = 5\%$) and closer stirrup spacing ($s = 75$ mm). In this way, the control models would fail in punching shear. However, these flat plate models differed in other details (type of shear reinforcement) as follows:-

1. **HSC-RL**: **H**igh **S**trength **C**oncrete flat plate model without shear reinforcement was tested under **R**epeated **L**oad.
2. **HSC-S-CS-RL**: **H**igh **S**trength **C**oncrete flat plate model with **S**hear reinforcement type **C**losed **S**tirrups was tested under **R**epeated **L**oad.
3. **HSC-S-SS-RL**: **H**igh **S**trength **C**oncrete flat plate model with **S**hear reinforcement type **S**hear **S**tuds was tested under **R**epeated **L**oad.
4. **HSC-S-BB-RL**: **H**igh **S**trength **C**oncrete flat plate model with **S**hear reinforcement type **B**ent **B**ars was tested under **R**epeated **L**oad.

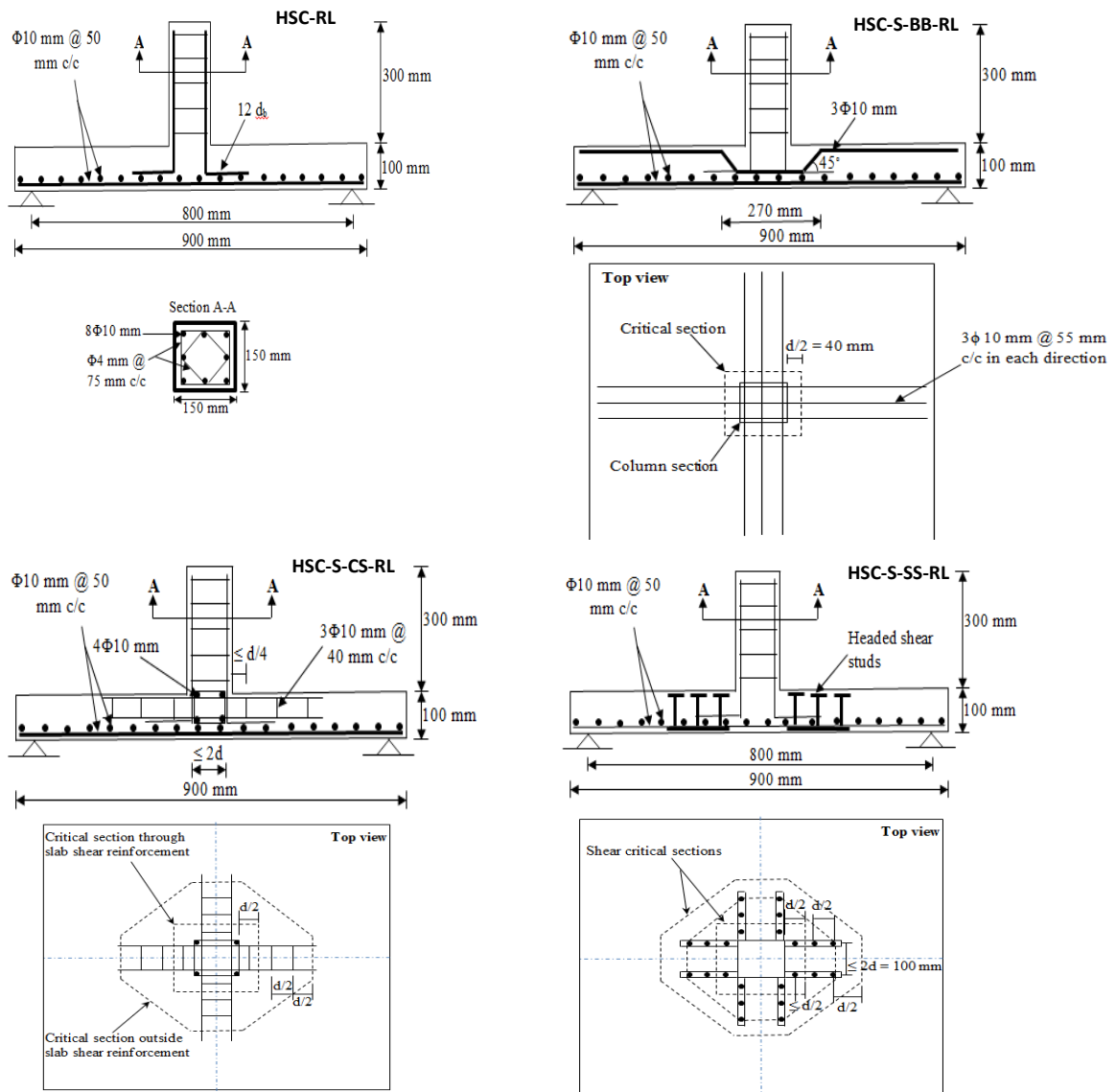

Fig.2:- Details of flat plate models (HSC-RL, HSC-S-CSRL, HSC-S-SS-RL and HSC-S-BB-RL).

2.2 Properties of Materials

Materials (fine aggregate, coarse aggregate, cement and silica fume) have used in preparing the concrete were tested according to the standard specifications. To produce HSC with silica fume a high range water reducer was used. It was based on polycarboxylic ether and had the trade mark “Glenium 54”. (Glenium 54) produced by (BASF) company. The normal dosage for (Glenium 54) as specified by the producer is (0.5 - 2.5) liter per (100 kg) of cement. The dosage used by the present investigation was (1.9 liter/100kg of cement). The average compressive strength of cylinders f'_c and cubes f'_{cu} for HSC at 28 days are 70.78 MPa and 82.10 MPa, respectively. The compressive strength test of concrete cylinders and cubes were carried out in accordance with **ASTM C39/C39M-05 (ASTM, 2005)** and **BS1881-part 116:2000 (BS, 2000)**. The steel reinforcing bars were in two sizes. The average yield stresses were 422 MPa for the bars size ϕ 10 mm and 510 MPa for the bars size ϕ 4 mm. Tensile test of steel bars were performed according to **ASTM A496-02 (ASTM, 2002)**.

2.3 Headed Shear Stud

The preparation of headed shear studs was more complex than other material because the selection of the shape and size and properties of the shear stud should be match the requirements and limitations of the **ACI-318-14**. The stud has a steel strip (5x35 mm) (thickness x width) and an anchor head welded to its bottom and top, respectively. Deformed steel bar ϕ 10 mm was used as stud the anchor head which has a diameter ($\geq \sqrt{10} \times$ diameter of stud =35 mm) as shown in Fig.3. The steel strip acts as an anchor and spacer, fixing the studs in a vertical situation at the suitable space in the formwork till the concrete is cast. To define the mechanical properties of the steel plate, a total number of three tensile samples were taken. The samples fabricated according to **ASTM-A370**. The average values of yield stress = 322 MPa, ultimate strength = 445 MPa.



Fig. 3:- Configuration of shear studs.

2.4 HSC Mix Design

The high strength concrete (HSC) is designed according to American method of mix proportions selection (**ACI Committee 211.4R, 2008**) and (**Hameed, 2010**). The mix proportion are given in Table 1.

Table 1:- The mix proportion of high strength concrete.

Cement kg/m ³	Silica fume (kg/m ³)	Sand kg/m ³	Gravel kg/m ³	Water kg/m ³	w/cm Ratio	HRWR/Glenium54 (L/m ³)
442	78	739	1067	130	0.25	8.4

2.5 HSC Mixing Procedure

HSC was mixed according to **ACI 363R-97 (ACI 363R, 1997)**. The HSC mixing procedure is stated as follows:-

1. Mix silica and cement in dry condition.
2. Place half quantity of coarse and fine aggregate in mixer.
3. Add all the (Portland cement+silica).
4. Rest of fine and gravel were added.
5. Add all water in mixer.
6. Mixed for three minutes.
7. Add the Glenium54.
8. Mixed for three minutes.

2.6 Test Procedure

All models were tested in a universal testing machine with capacity of 600 kN under repeated loads up to ultimate load. These models were tested under concentrated loading and simply supported along all four edges. The top surface of the column stub for all models was grinded by using an electrical grinder to get a clean suitable surface and was provided with rubber plates to make the column's surface flat and to avoid non-uniform stress distribution.

The repeated load was applied cyclic up to failure. All cycles consist of two steps, first step was loaded up to selected level from P (where $P=220$ kN) and second step was unloaded to zero. The selected levels of load are ($0.2P$, $0.4P$, $0.6P$, $0.8P$, $0.85P$, $0.9P$, $0.95P$, P , $1.05P$, $1.1P$, up to failure of model). Each level of load consist three cycles, as shown in Fig.4.

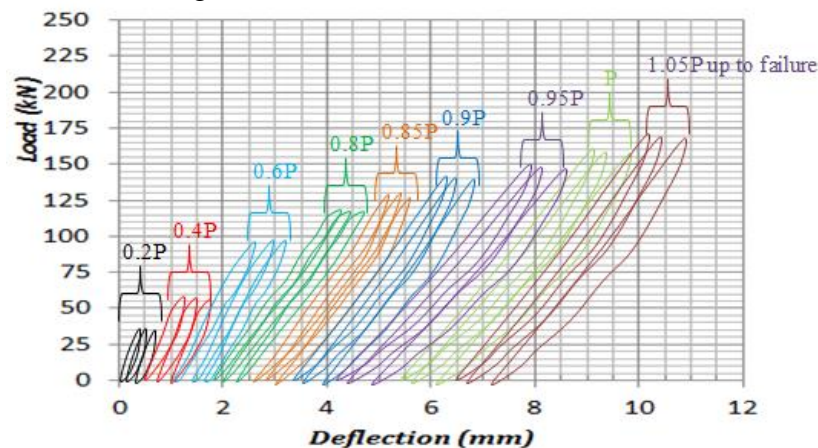

Fig.4:- Explanatory load-deflection curve of model was tested under repeated load.

The deflections were measured by a Linear Variable Differential Transducers (LVDT). Four vertical LVDT were used; one at the center point of the model; two at center of each orthogonal directions for the one quarter of model and one at the center of the diagonal direction for the same quarter of model. The load was applied in stages with 5 kN for repeated load test. The first cracking load and its location were recorded.

At each load increment, observations of crack development on the concrete models were traced by pencil. Also, for each model, maximum crack width and its location were measured. The strain of concrete were measured by an extensometer of accuracy (0.002 mm). Two pairs of demec discs were used to monitor the strain of concrete at selected levels of loading at several points around the critical section in tension face for all reinforced concrete models.

The deflections and strains were measured for each step. The loading was continued until ultimate load. The failure of models was declared when no further increase of the loading readings was recorded with noticeable large deflection in addition to large flexure and shear cracking. Fig.5 shows a flat plate model that tested in the laboratory of Babylon University.



Fig.5:- Test setup.

3. Experimental Results and Discussion

Results of test were discussed considering the ultimate load, the load- deflection curve, deflected shape, cracking behavior, failure mode and concrete strain around the critical section in tension face of model.

3.1 Ultimate Load and Deflection

Four LVDT were placed one at the center, two at (200 mm) from the center of model in both directions and one at the quarter of diagonal direction to measure the deflection. The recorded ultimate load and deflection are presented in Table 2 for flat plate models.

Table 2:- Deflection at ultimate load for each flat plate model.

Flat plate models symbol	Ultimate load P_u kN	Deflection, mm				
		Center	1/4th Point			Average of X and Z directions
			Diagonal	X-Direction	Z-Direction	
HSC-RL	200	7.53	2.32	2.99	2.73	2.86
HSC-S-CS-RL	384	8.11	3.40	4.09	4.33	4.21
HSC-S-SS-RL	350	10.53	5.48	6.43	6.21	6.32
HSC-S-BB-RL	240	7.67	2.45	2.93	3.05	2.99

The shear reinforcement has a noticeable effect on increasing punching shear strength by about 92% and has a clear effect on increasing measured deflections as shown in Fig.6.

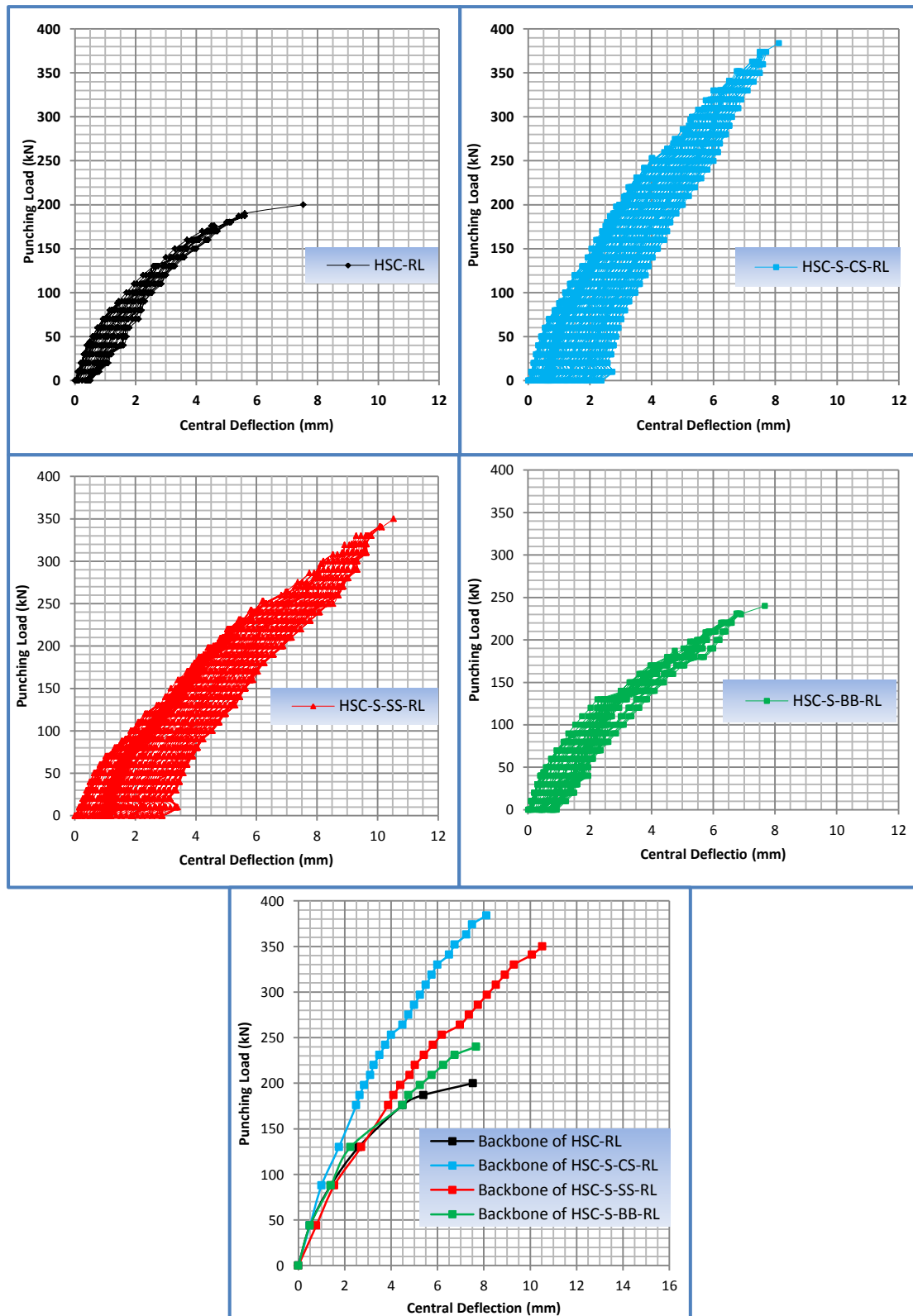

Fig.6:- Effect of using shear reinforcement on load-central deflection for HSC flat plate models.

HSC flat plate models with shear reinforcement type (closed stirrups with top and bottom flexural reinforcement, shear studs and bent bars) were tested under repeated

load (HSC-S-CS-RL, HSC-S-SS-RL and HSC-S-BB-RL, respectively) showed higher ultimate load when compared with the HSC flat plate model without shear reinforcement under repeated load (HSC-RL) by about (92%, 75% and 20%, respectively) and the deflection at the maximum punching load is higher (7.7%, 39.84% and 1.86%, respectively). Also, increase in residual deflection from 0.51 mm to (2.37, 2.9 and 0.93mm, respectively). Also, the bent bars shear reinforcement had limited effect on flat plate model punching shear strength and deformation capacity because it was caused by local crushing of the concrete under the bends of the bent bars.

This type of shear reinforcement was used because of its simplicity. But, the shear stud reinforcement is highly increase punching shear strength, ductility and rotation capacity of flat plate model. The closed stirrups have been found to be effective in enhancing the shear strength and ductility of flat plate model. It should engage longitudinal reinforcing bars in each corner to be fully effective. Therefore, it is concluded that the closed stirrups is a simple and cost-effective type of shear reinforcement. However, closed stirrups reinforcement was found to be more practical from a construction viewpoint. Hence, it is best types of shear reinforcement.

3.2 Deflected Shape

The 70% of the ultimate load of control model (HSC-RL) was considered as a service load for all flat plate model and the corresponding deflected shape along the X or Z-axis was drawn. At load 140 kN (at service load), the use of shear reinforcement in flat plate model decreases the deflection by about 36.67% and 31.82% when compared HSC-S-CS-RL with HSC-RL for central and mid side deflections; respectively as shown in Fig.7.

The deflected shape for HSC-S-SS-RL and HSC-S-BB-RL flat plate models in comparison with HSC-RL flat plate model showed that HSC-S-SS-RL and HSC-S-BB-RL flat plate models exhibited somewhat lesser deflection at central by about 6.67% and 3.33%, respectively and at mid side by about 18.18% and 9%, respectively. Therefore, it is concluded that the use of shear reinforcement in flat plate model increases stiffness and reducing the deflection at service load, but it increases ductility by increasing deflection at ultimate load.

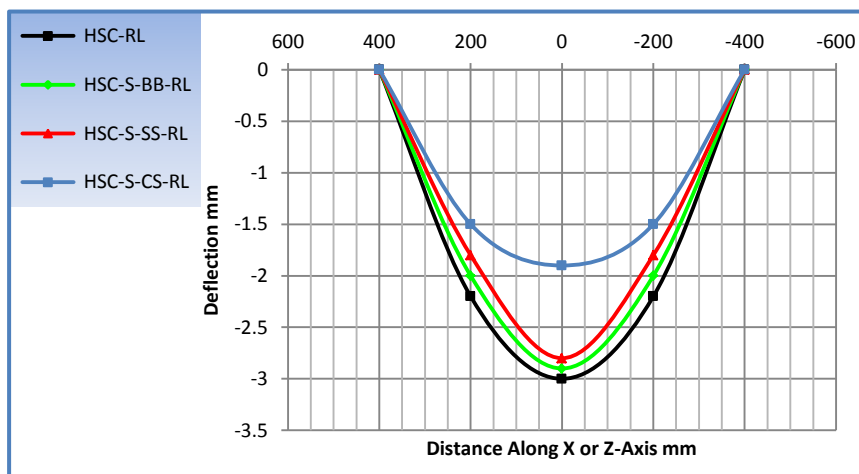

Fig.7:- Effect of using shear reinforcement on deflected shape along X or Z-axis at 140 kN for flat plate models tested under RL.

At service load (140 kN), the maximum deflection for all flat plate models within the limit of deflection of ACI 318-14 (ACI 318, 2014) which is equal to 4.44mm.

3.3 Cracking Behavior and Failure Mode

Table 3 listed the first cracking load and its percentage of the ultimate failure load, the max. width of crack where the service load equal 70% of ultimate load, maximum crack width at failure for flat plate models and failure mode, respectively.

Table 3:- Results of cracks for all flat plate models.

Flat plate model symbol	Ultimate load P_u (kN)	1 st Crack in tension face		P_{cr}/P_u %	Crack width at 70% P_u w_s (mm)	Max. crack width in tension face at failure w_m (mm)	Failure mode
		Load P_{cr} (kN)	Crack width w_{cr} (mm)				
HSC-RL	200	72	0.043	36.00	0.25	2.73	punching shear
HSC-S-CS-RL	384	90	0.035	23.43	0.18	2.30	punching shear within the shear reinforced area
HSC-S-SS-RL	350	80	0.040	22.86	0.21	2.50	punching shear
HSC-S-BB-RL	240	75	0.042	22.92	0.24	2.60	punching shear

The distance between the failure surface and the column face in tension and compression faces of all flat plate models and the angle of diagonal cracks of the punching cone are presented in Table 4.

Table 4:- The distance between the failure surface and the column face and the angle of diagonal cracks of the punching cone for all flat plate models.

Flat plate model symbol	Distance between the failure surface and the column face (mm)		Angle of diagonal cracks of the punching cone
	In tension face	In compression face	
HSC-RL	1.5d*	0	43.6°
HSC-S-CS-RL	3.5d	0.9d	29°
HSC-S-SS-RL	2.25d	0	32.41°
HSC-S-BB-RL	d	0	55°

d* = The average effective depth of slab = 70 mm.

It can be observed from Table 4 and Fig. 8 that the distance between the column face and the surrounding failure crack was larger in case of flat plate models with shear reinforcement. Also, a higher number of radial cracks were observed for flat plate models with shear reinforcement in comparison with control flat plate models.

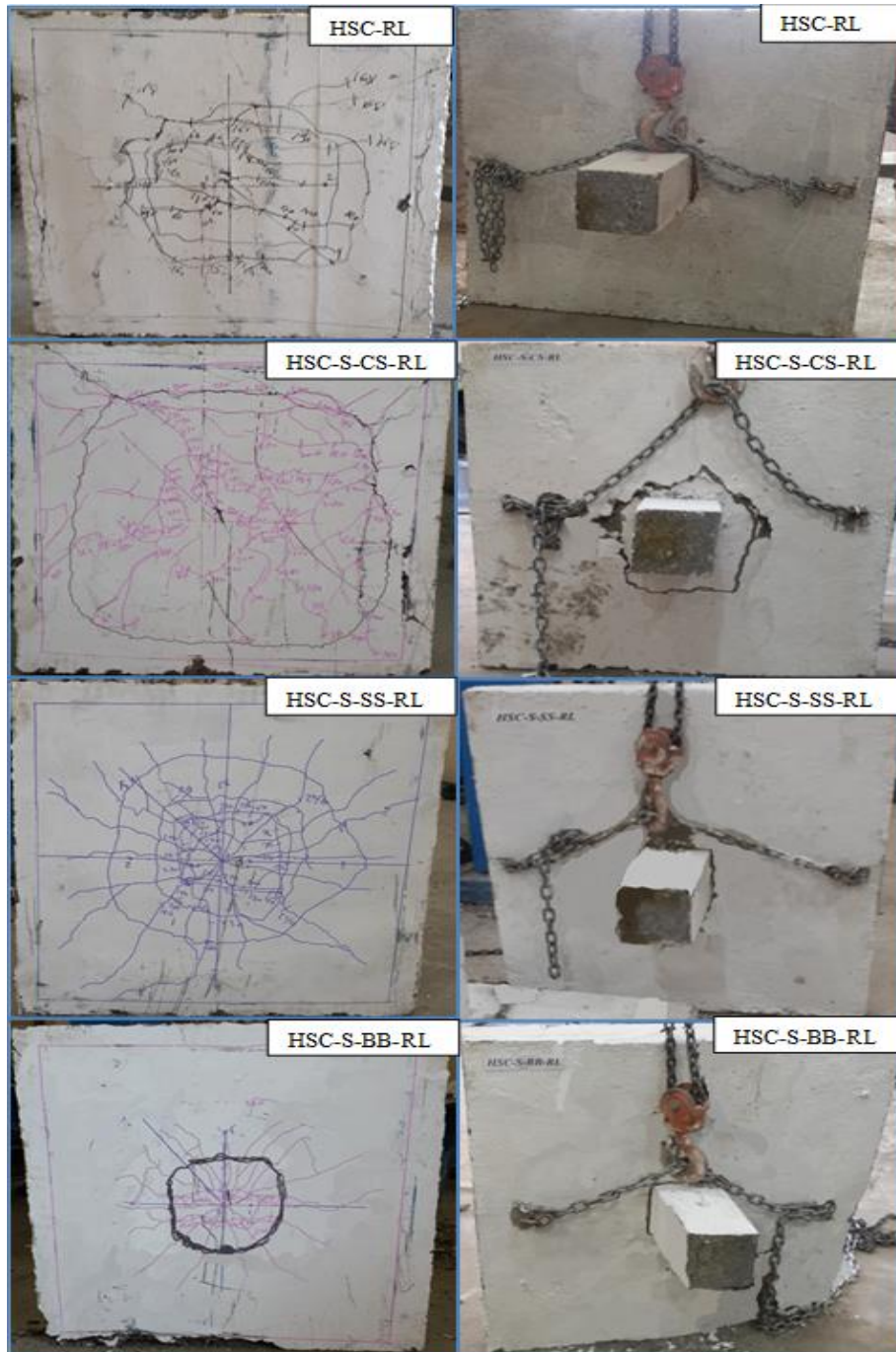

Tension face Compression face

Fig.8:- Cracks patterns at failure for the tested flat plate models.

3.4 First Crack Load

The use of shear reinforcement in flat plate model gave improvement in first cracking load in comparison with flat plate model without shear reinforcement. Flat plate models HSC-S-CS-RL, HSC-S-SS-RL and HSC-S-BB-RL showed improvement in first cracking load by about 25.00%, 11.11% and 4.17%; respectively when compared with HSC-RL. This is due to increase the ductility of flat plate by shear reinforcement.

3.5 Crack Width

The use of shear reinforcement in flat plate models reduces crack width as shown in Fig.9. The maximum cracks width at service load (70% P_u) of HSC-S-CS-RL, HSC-S-SS-RL and HSC-S-BB-RL model is less than HSC-RL model by about 28%, 16% and 4%, respectively.

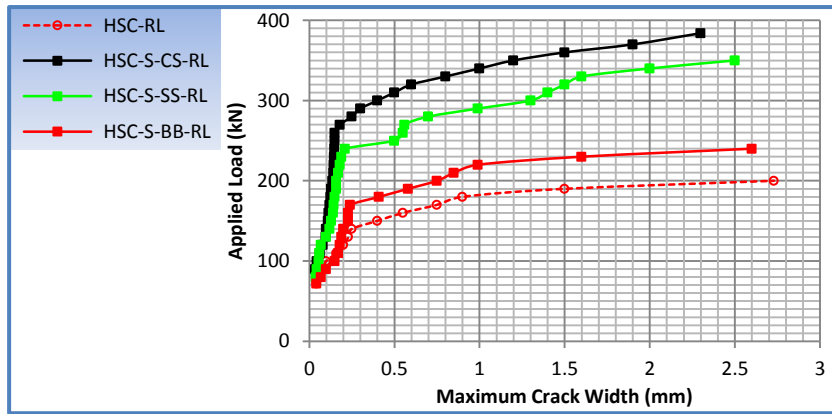

Fig.9:- Effect of shear reinforcement on load-maximum crack width for flat plate models.

At service load (70% P_u), the maximum crack width for all flat plate models within the limit of crack width of ACI 318M-14 (ACI 318M, 2014) which is equal to 0.41 mm for the steel reinforced concrete.

3.6 Concrete Strain

From Fig.10, the best strengthening technique (type of shear reinforcement) for the lowest normal concrete strain at service load is adding of shear reinforcement type closed stirrups (HSC-S-CS-RL). The normal concrete strain of HSC-S-CS-RL model at 140 kN is less than HSC-RL model by about 66.67%.

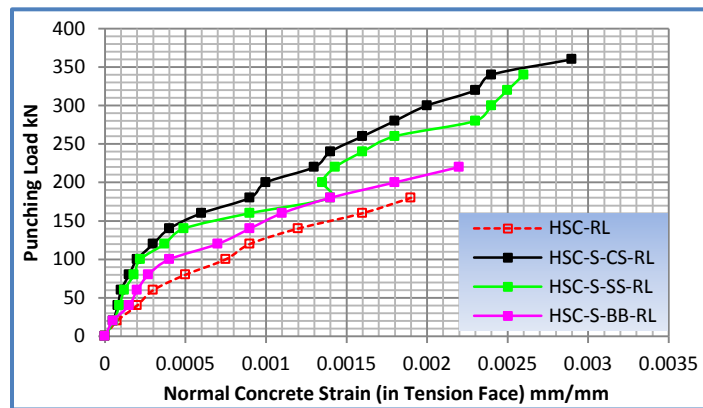

Fig.10: Effect of shear reinforcement on load-concrete tensile strain for flat plate models.

4. Finite Element Modeling

Finite element analysis, as used in structural engineering, determines the overall behavior of a structure by dividing it into a number of single elements, each of which has well defined mechanical and physical properties. Modeling of the constitutive material properties is an important aspect of any finite element analysis. The constitutive model should correctly describe the behavior of the material under uniaxial and multiaxial states of loading. Finite element modeling and analysis were carried out to simulate the behavior of the four tested flat plates from linear through non-linear response and up to failure, using the ABAQUS (Version 6, copyright 2013) computer program. The choice of the proper element type is very important in the finite element analysis. The chosen element type depends upon the geometry of the structure and the number of independent space coordinates necessary to describe the problem. Each component of flat plate should be modeled by the proper element type and then each type of element should be provided by the properties according to the material of that component. In the present study, three-dimensional model was used to analyze flat plate. The concrete was divided in its length, width and depth into brick elements (Solid elements) (C3D8R, 8-node linear brick, reduced integration). Element

type (Truss elements) (T3D2, two-node linear displacement, Truss elements) was used to model steel reinforcement. These truss elements are embedded into continuum elements to model the bond strength between reinforcement and concrete. Three dimensional 4-node tetrahedral element (C3D4, 4-node linear tetrahedron) with three displacement components at each node in the nodal x, y and z directions was used to idealize the shear stud, similar to the one used by (Broms, 2007).

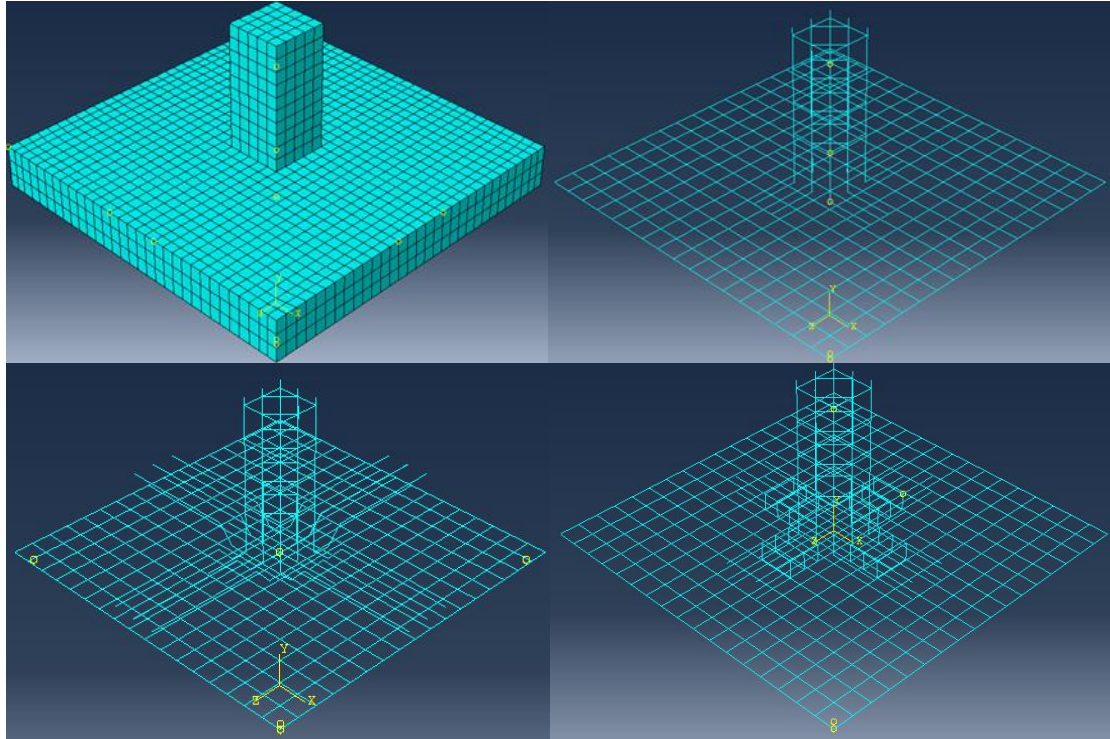

Fig.11:- Mesh of concrete and steel reinforcement for HSC-RL, HSC-S-BB-RL and HSC-S-CS-RL models.

5. Numerical Results

The numerical results of ultimate loads, load-deflection curves and first cracking loads are concerned to compare them with those of experimental work. This comparison was conducted to verify the numerical model. Table 5 shows a comparison between experimental and numerical ultimate loads for the study models. Table 6 shows a comparison between numerical and experimental results of the first cracking load for flat plate models.

Table 5:- Comparison between experimental and numerical ultimate loads for flat plate models.

Flat plate models symbol	Ultimate load P_u kN		Difference ratio %
	Experimental	ABAQUS	
HSC-RL	200	214	7.00
HSC-S-CS-RL	384	385	0.26
HSC-S-SS-RL	350	373	6.57
HSC-S-BB-RL	240	242	0.83

Table 6:- Experimental and numerical first cracking loads for flat plate models.

Flat plate models symbol	1st Cracking load kN		$\frac{P_{cr}num.}{P_{cr}exp.}$
	Experimental $P_{cr}exp.$	Numerical $P_{cr}num.$	
HSC-RL	72	75	1.04
HSC-S-CS-RL	90	91	1.01
HSC-S-SS-RL	80	82	1.02
HSC-S-BB-RL	75	76	1.01

In general, the ultimate loads predicted by the numerical analysis are greater than those of experimental testing. The percentage of difference for the ultimate loads is between (0.26-7) % for all the models as shown in Table 5. The first cracking load obtained from numerical data for all cases showed results higher than the experimental data recorded with average differences not more than 2.28% for all flat plate models. Fig. 12 show a comparison between experimental and numerical results for the load versus central deflection curves of all flat plate models.

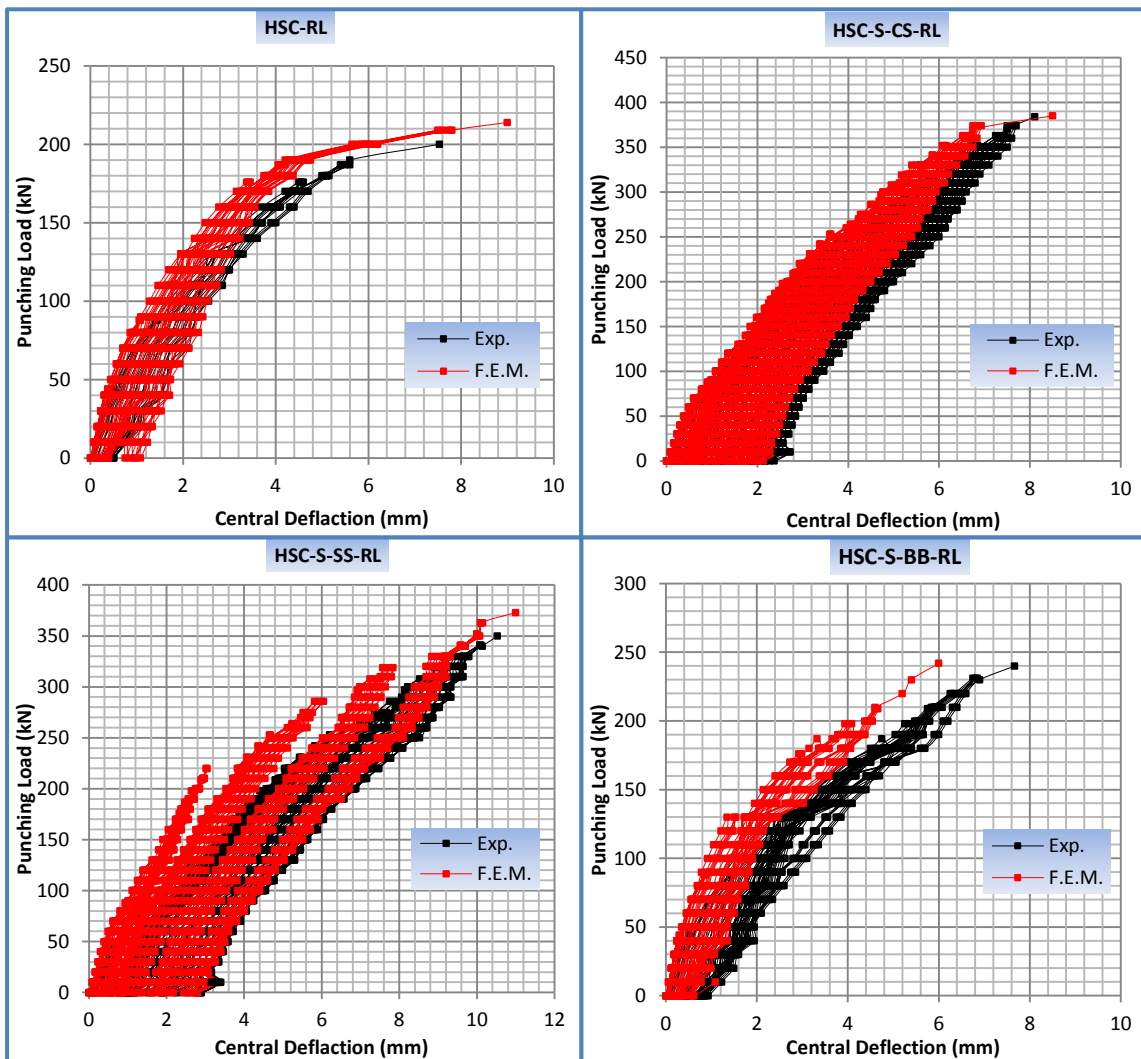

Fig. 12:- Load-deflection curves of all flat plate models.

This comparison shows in general that the numerical models are stiffer, and the numerical analysis gives a smaller value for the deflection and a greater value for ultimate load with a little difference in the ultimate load values. This may be caused by the following:-

1. The finite element model is based on assumed displacement field that means stiffer behavior than actual one.
2. The concrete of experimental models is not perfectly homogeneous as assumed in the numerical models.
3. Micro-cracks which may have occurred in concrete due to shrinkage reduce the stiffness in some degree.
4. Cracks in plastic behavior of each element are only tested at gauss points which give overestimate of ultimate load and stiffer response.

6. Conclusions

Based on the results of the experimental work and finite element analysis for the tested flat plate models, the following remark points can be concluded:-

1. Shear reinforcement improves the punching shear strength and the deformation capacity of flat plate. All of the closed stirrups, the headed shear studs and the bent bars improved the punching shear strength by about 92%, 75% and 20%, respectively. It also increased the deformation capacities by about 7.7%, 39.84% and 1.86%, respectively when compared with flat plate without shear reinforcement.
2. Closed stirrups is best type of shear reinforcement since this type of shear reinforcement is highly increases punching shear strength, deformation capacity, simple and cost-effective.
3. Using shear reinforcement in flat plate model increased stiffness by reducing deflection at service load, on the other hand it increased ductility by increasing deflection at ultimate load.
4. The distance between the column face and the surrounding failure crack perimeter was larger in case of flat plate models with shear reinforcement by about 133%, (about 3.5d). Also, a higher number of radial cracks were observed for flat plate models with shear reinforcement in comparison with flat plate models without shear reinforcement.
5. The 3D FE analysis by ABAQUS program shows that it is possible effectively to simulate the real behavior of flat plate models, with a certain degree of accuracy. One of the most important things in this analysis is the correct choice of the adequate material modelling.
6. The ultimate numerical loads get it by FE analysis agree well when compared by the corresponding values of experimental tested flat plate models; where the average difference of the ultimate load was less than 3.67% for all analyzed models.

7. References

ABAQUS Theory Manual, 2013 "*User Manual and Example Manual*", Version 6, Providence.

ACI committee 318, 2014 "*Building Code Requirements for Structural Concrete and Commentary (ACI 318M-14)*", American Concrete Institute, Detroit. MI. U.S.A.

ACI 363R-92, 1997 "*State-of-the-Art Report on High-Strength Concrete*", American Concrete Institute.

ACI committee 211.4R, 2008 *"Guide for Selecting Proportions for High-Strength Concrete with Portland Cement and Fly Ash"*, American Concrete Institute. Detroit.

ASTM A496-02, 2002 *"Standard Specification for Steel Wire, Deformed, for Concrete Reinforcement"*, ASTM Committee A-1 on Steel, Stainless Steel, and related Alloys, West Conshohocken, PA 19428- 2959, United States, 5 pp.

ASTM A 370-07a, 2007 *"Standard Test Methods and Definitions for Mechanical Testing of Steel Products"*, Annual Book of ASTM.

ASTM C 39/C 39M-05, 2005 *"Standard Test Method for Compressive Strength of Cylindrical Concrete Specimens"*, Annual Book of ASTM Standards, Vol. 04.02 Concrete and Aggregates, West Conshohocken, PA, United States, 7 pp.

ASTM C 192/C 192M-05, 2005 *"Standard Practice for Making and Curing Concrete Test Specimens in the Laboratory"*, Annual Book of ASTM Standards, American Society for Testing and Materials, pp. 1-8.

Broms, C. E., 2000 *"A method to Avoid the Punching Failure Mode"*, pp. 117-124, Stockholm, Sweden.

Broms, C.E. , 2007 *"Ductility of Flat Plates: Comparison of Shear Reinforcement Systems"*, ACI Structural Journal, 104(6), pp. 703-711.

BS 1881-Part 116:1983, 2000 *"Method for Determination of Compressive Strength of Concrete Cubes"*, British Standards Institute BSI, London, 11 pp.

Corley, W. G. and Hawkins, N. M., 1968, 1974 *"Shear Head Reinforcement for Slabs"*, ACI Journal, Vol. 65, No. 10, October, pp. 811-824.

Gardner, N.J. and Shao, X.Y., 1996 *"Punching Shear of Continuous Flat Reinforced Concrete Slabs"*, ACI Structural Journal, Vol. 93(2), pp. 218-228.

Islam, S. and Park, R., 1976 *"Tests of Slab-Column Connections with Shear and Unbalanced Flexure"*, Journal of the Structural Division, Proceedings of the American Society of Civil Engineers, Vol. 102, No. ST3, March, pp. 549-569.

Robertson, I. N., Kawai, T., Lee, J. and Johnson, G., 2002 *"Cyclic Testing of Slab-Column Connections with Shear Reinforcement"*, ACI Structural Journal, Vol. 99, No. 5, pp. 605-613.

Yogendran, V., Langan, B.W., Haque, M.N. and Ward, M .A., 2007 *"Silica Fume in High-Strength Concrete"*, ACI Materials Journal, pp.124-129.