

Types of Operating Systems

There are Many Operating Systems those have be Developed for Performing the Operations those are requested by the user. There are Many Operating Systems which have the Capability to Perform the Requests those are received from the System. The Operating system can perform a Single Operation and also Multiple Operations at a Time. So there are many types of Operating systems those are organized by using their Working Techniques.

1) Serial Processing:

The Serial Processing Operating Systems are those which Performs all the instructions into a Sequence Manner or the Instructions those are given by the user will be *executed by using the FIFO manner* means First in First Out. All the instructions those are entered first in the system will be executed first and the instructions those are entered later will be executed later. For running the instructions the program counter is used which is used for executing all the instructions. In this the program counter will determines which instruction is going to execute and the which instruction will be execute after this. Mainly the punch cards are used for this. In this all the jobs are firstly prepared and stored on the card and after that card will be entered in the system, all the instructions will be executed one by one.

But the main problem is that a user doesn't interact with the system while he is working on the system, means the user can't be able to enter the data for execution.

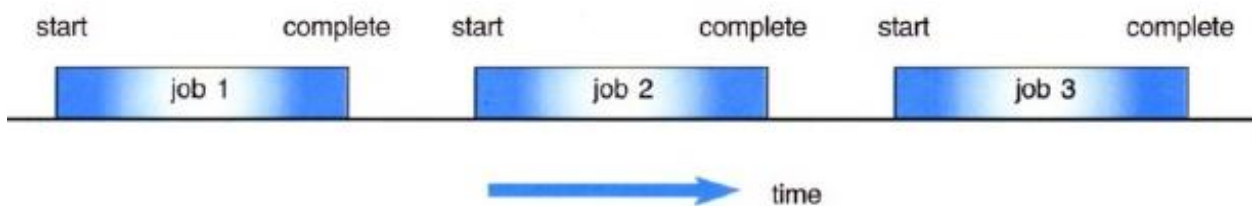

2) Batch Processing:

The Batch processing is **same as the serial processing technique**. But in the batch processing **similar types of jobs are firstly prepared** and they are stored on the card. and that card will be submit to the system for the processing. The system then perform all the operations on the instructions one by one. And a **user can't be able to specify any input**. And operating system wills increments his program counter for executing the next instruction. The **main problem is that the jobs those are prepared for execution must be the same type** and **if a job requires for any type of input then this will not be possible for the user**. And many **time will be wasted for preparing the batch**. The batch contains the jobs and all those jobs will be executed without the user intervention. And **operating system will use the LOAD and RUN operation**. This will first **LOAD the job from the card** and **after that he will execute the instructions** by using the RUN command. The speed of the processing the job will be depend on the jobs and the results those are produced by the system in difference of time which is used for giving or submit the job and the time which is used for displaying the results on the screen.

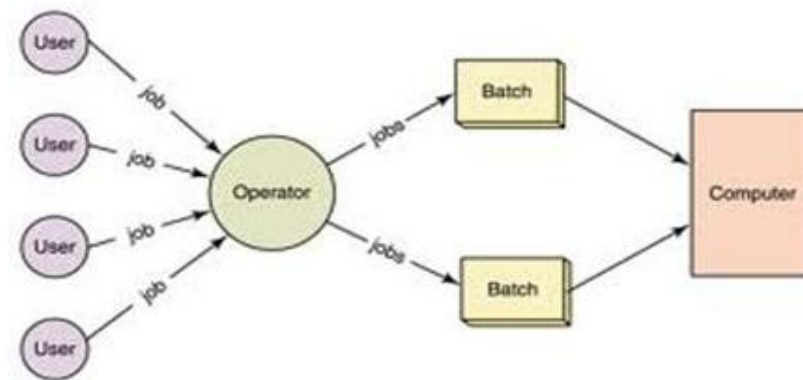

3) Multi-Programming:

As we know that in the Batch Processing System there are multiple jobs execute by the system. The system first prepare a batch and after that he will execute all the jobs those are stored into the batch. But the main problem is that there will be the wastage of the time when we are preparing the batch and the CPU will remain idle at that Time. But with the help of **Multi programming we can execute multiple programs on the system at a time** and in the Multi-programming the CPU will never get idle, because with the help of Multi-Programming we can execute Many Programs on the System and

when we are working with the program then we can also submit the second or another program for running and the CPU will then execute the second program after the completion of the first program. And in this we can also specify our input means a user can also interact with the system. The Multi-programming operating systems never use any cards. But the operating system also uses the process of allocation and de-allocation of the memory means he will provide the memory space to all the running and all the waiting processes. There must be the proper management of all the running jobs.

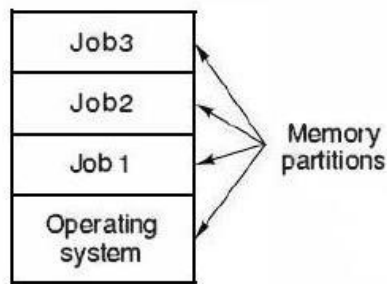

A multiprogramming system with three jobs in memory.

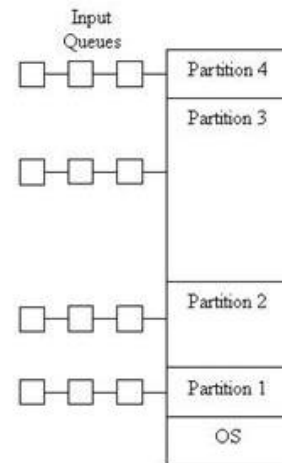

4) Real Time System:

There is also an Operating System which is known as Real Time Processing System. In this Response Time is already fixed. Means time to Display the Results after Possessing has fixed by the Processor or CPU. Real Time System is used at those places in which *higher and Timely Response required*. These Types of Systems are used in Reservation. So when we specify the Request, the CPU will perform at that Time.

5) Distributed Operating System:

Distributed Means Data is Stored and Processed on Multiple Locations. When a Data is stored on to the Multiple Computers, those are placed in Different Locations. A distributed operating system manages a group of independent computers and makes them appear to be a single computer. The development of networked computers that could be linked and communicate with each other gave rise to distributed computing. Distributed computations are carried out on more than one machine. When computers in a group work in cooperation, they make a distributed system.

If we want to Take Some Data From other Computer, Then we uses the Distributed Processing System. And we can also Insert and Remove the Data from out Location to another Location. In this Data is shared between many users. And we can also Access all the Input and Output Devices are also accessed by Multiple Users.

6) Multiprocessing:

Generally a Computer has a Single Processor means a Computer have a just one CPU for Processing the instructions. But if we are Running multiple jobs, then this will decrease the Speed of CPU. For Increasing the Speed of Processing then we uses the Multiprocessing, in the Multi Processing there are two or More CPU in a Single Operating System if one CPU will fail, then other CPU is used for providing backup to the first CPU. With the help of Multi-processing, we can Execute Many Jobs at a Time. All the Operations are divided into the Number of CPU's. if first CPU Completed his Work before the Second CPU, then the Work of Second CPU will be divided into the First and Second.

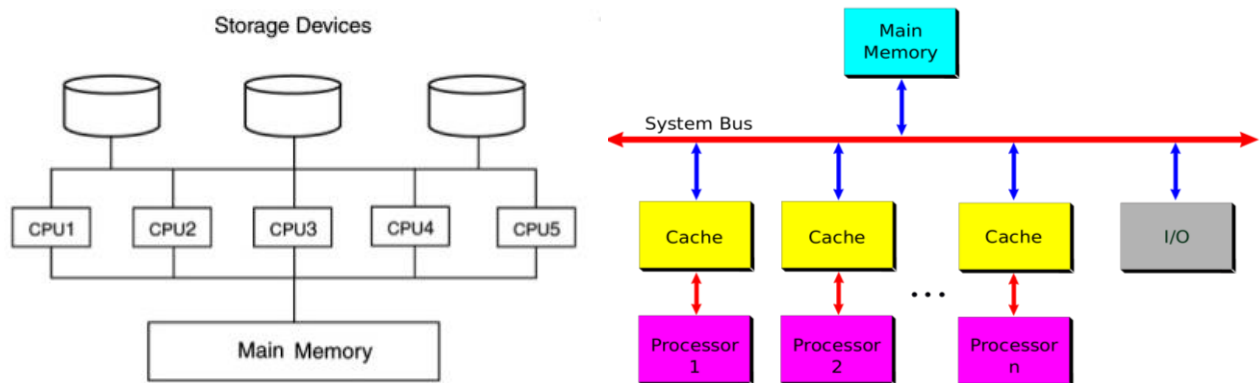

7) Parallel operating systems:

They are used to *interface multiple networked computers to complete tasks in parallel*. The architecture of the software is often a UNIX-based platform, which allows it to coordinate distributed loads between multiple computers in a network. Parallel operating systems are able to use software to manage all of the different resources of the computers running in parallel, such as memory, caches, storage space, and processing power. Parallel operating systems also allow a user to directly interface with all of the computers in the network.

frequently make a system call to an OS function or be interrupted by it. Operating systems can be found on almost any device that contains a computer from cellular phones and video game consoles to supercomputers and web servers.

B) Multi tasking:

Multi tasking operating systems enables a single user to have two or more applications open at the same time. Multi tasking operating systems can be divided into three general types depending on the type of computer and the type of applications that will be run. These are Real time operating systems, Single user-Multi tasking, Multi user operating systems.

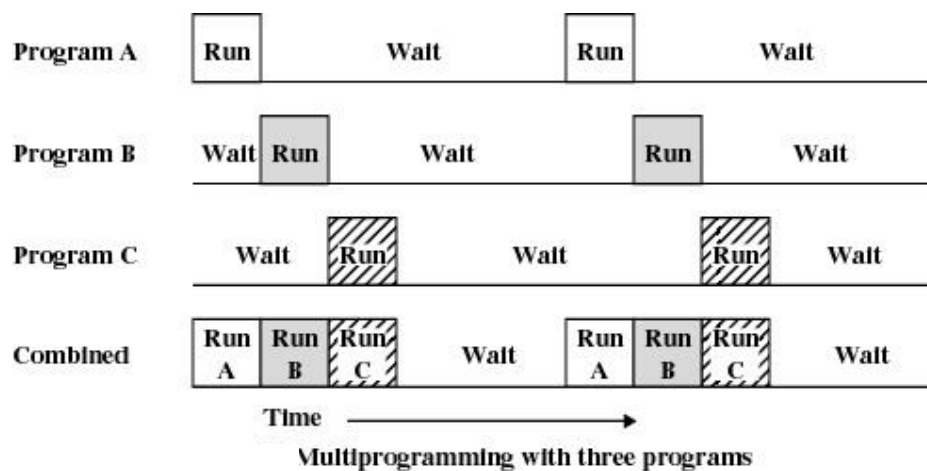

B-1/ Real time operating systems (RTOS):

They are mainly used to control machinery, scientific instruments, industrial systems, etc. Here the user does not have much control over the functions performed by the RTOS. The main objective of real-time operating systems is their quick and predictable response to events. Such systems as ECG devices.

B-2/ Single user-Multi tasking:

This is the type of operating system most people use on their desktop and laptop computers today. They are the systems that allow a single user to work with it with running different applications at the same time. Windows of Microsoft and Macintosh of Apple are examples of operating systems that will let a single user have several programs in operation at the same time. For example, it's entirely possible for a Windows user to be

writing a note in a word processor while downloading a file from the Internet while printing the text of an e-mail message.

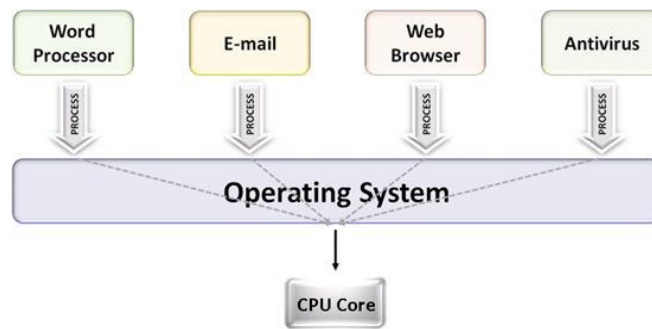

B-3/ Multi user operating systems:

They give access at the same time to the resources on a single computer to many users, there exists a control from the system to its resources. This O.S. allows many different users to take advantage of the computer's resources simultaneously. The operating system must make sure that the requirements of the various users are balanced, and that each of the programs they are using has sufficient and separate resources so that a problem with one user doesn't affect the entire community of users. Unix, VMS, Linux and mainframe operating systems, such as *MVS*, are examples of multi-user operating systems.

