

International Journal of Engineering Sciences & Research Technology

(A Peer Reviewed Online Journal)

Impact Factor: 5.164



Chief Editor

Dr. J.B. Helonde

Executive Editor

Mr. Somil Mayur Shah

INTERNATIONAL JOURNAL OF ENGINEERING SCIENCES & RESEARCH TECHNOLOGY

A REVIEW ON VIBRATION CONTROL STRATEGIES OF AUTOMOBILE SUSPENSION SYSTEM

Ali T. Hassan*¹, Ahmed Abdullah Hassan Al-Rajihy ²&Abdulkareem Abdulrazzaq Al
Humdany³

^{*1}Department of Mechanical Engineering, College of Engineering, University of Kerbala, Iraq

^{1&2}Department of Mechanical Engineering, College of Engineering/Almussyab, University of
Babylon, Iraq

DOI: 10.5281/zenodo.3522948

ABSTRACT

The objective of this paper is to focus on the studies in field of automobile suspension system control strategies and the methods that were used to evaluate the optimal values for the suspension system parameters such as spring stiffness, damper damping coefficient, tire stiffness, tire damping coefficient. There are many types of controllers to improve the vibration control of automobile suspension system when undergoes to external excitation from road profile, such as proportional-integral- derivative (PID), linear quadratic regulation (LQR), H infinity, robust control and Fuzzy controller. And there are three methods of suspension system strategies; passive system, active system and semi –active system. The semi active control included; magneto rheological damper and electro rheological damper, in this case; the effective area in which the oil damping flowing through was varied according to road disturbance. This study concluded that using PID, LQR, H infinity and Fuzzy controller which had been improved the performance of suspension system strongly, especially, the improvement in the time of steady state response whereas by using of PID and Fuzzy controllers led to decrease the time of steady state response and reduced the maximum overshoot.

It can be concluded that using Simulink program to solve the equation of motion of quarter automobile suspension system is very important due to complexity of solving by traditional methods which used to solve these cases.

KEYWORDS: Suspension system control strategy, Steady state response, Maximum overshoot, Ride comfort, Road handling, Magneto rheological damper.

1. INTRODUCTION

The stability of vehicle when it moving above different terrain is very important criterion in addition to ride comfort of passengers. Traffic accidents in the world wide lead to losing people their lives or suffer a non-fatal injury. The ride comfort and road handling of automobiles are majorly achieved by their suspension systems, which represent the connection between automobile body and road [1]. The main purpose of the vehicle suspension system is to support and separate automobile body from the wheels and relatively allows for movement between the components. It is certainly rated by its ability to achieve suitable ride comfort and good automotive holding from road disturbance and improve passenger comfort. There are many reasons caused the disturbance such as road surface terrain, aerodynamic forces, non-uniformity of the wheel, tire assembly, and even or barking forces.

2. TYPES OF SUSPENSION SYSTEMS

There are many constructions of suspension system as illustrated below

A- Beam Axle

This type has ends produced to allow the assembly of kingpins with vertically manner to enable the wheels to rotate with vehicle steering. Two downwards curved profile ends of the leaf spring. Figure (1) is illustrated Beam axle suspension system.

B- Dual-Beam Suspension

Dual-beam suspension system may be considered as "independent suspension system" in which, the two wheels are not directly connected. The major advantage of this type is isolated the shock loads from road profile to develop the ride comfort, the disadvantage of this type is tire edge wear and wheel scrubbing due to change with vehicle vertical movement , figure (2) shows this kind of suspension [2].

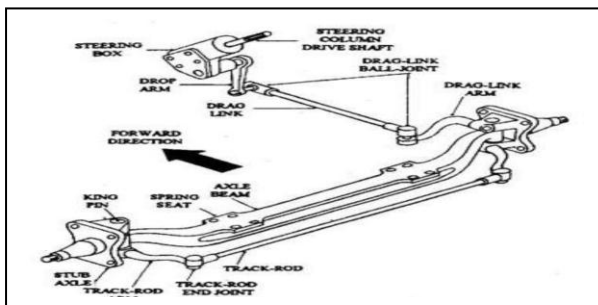

Figure. (1) Beam axle suspension [2]

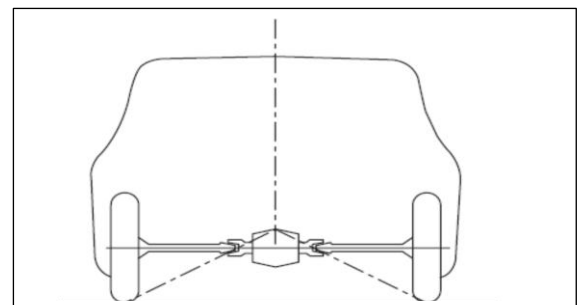

Figure. (2) Dual beam suspension [2]

C-Double Wishbone Suspension

The double wishbone suspension system composed from two equalized wishbone configuration elements imposed one over the second. The closed extreme points (ends) of both wishbone links are hinge mounted at the top and bottom of the automobile steering [3], Fig. (3) is illustrated the double wishbone suspension system.

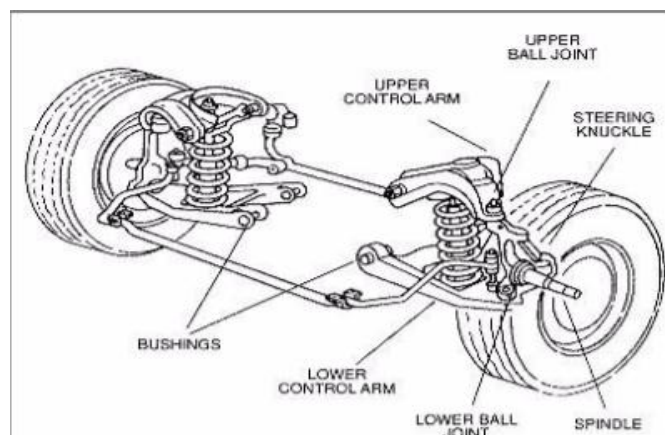

Figure. (3) Double wishbone suspension system [3]

D-Macpherson Strut Suspension

By an American automotive engineer named Steele Mac Pherson, a Macpherson strut was invented, this type of suspension system is lighter weight than beam suspension and the same cost and weight of short/ long arm type, the MacPherson is an independent suspension [4]. Figure (4) shows Mac Pherson strut suspension.

Another type of suspension system is a multi-linked suspension system; this type used in heavy vehicle and is illustrated in Fig. (5).

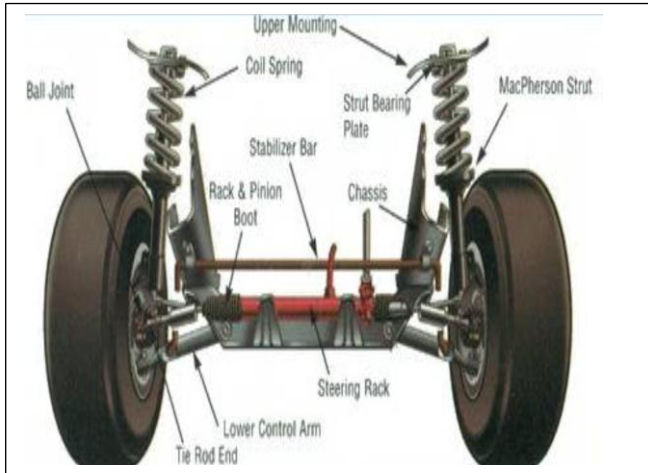

Figure. (4) Macpherson strut suspension system [4]

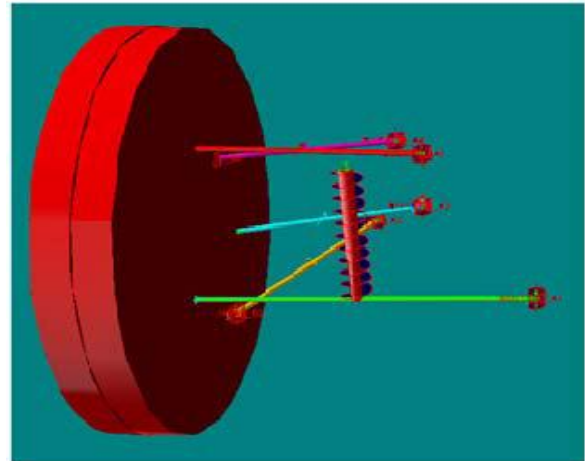

Figure. (5) Multi linked suspension system [5]

3. TYPES OF SUSPENSION SYSTEM CONTROL

There are three type of vibration control of automobile suspension system strategies; which include of passive, active and semi active, will be illustrated below

A-Passive Control

A passive control system strategy is the simple device of control system, it is with automobile suspension in a proper manner and without external power required to operate, the passive control system considered the first technique to control of vibration in automobile suspension system, there were a lot of researches had been achieved in this field. The traditional passive control for the automobile suspension system of springs and conversional dashpots are classified as passive. The isolation or reducing vibration, which are produced, for instance, by industrial machine, or other vibrators are accomplished in order to reduce the force transmitted by these to the suspension. All traditional suspension composed of springs and conversional dashpots are classified as passive.

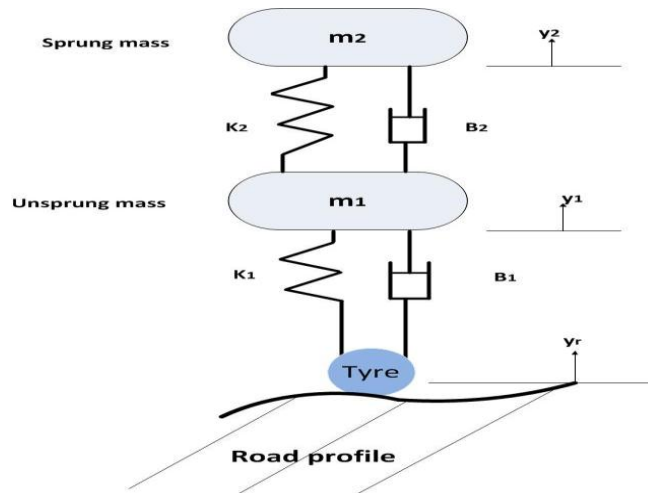

Figure. (6) Schematic of passive suspension system

The dynamic behavior of a passive automobile suspension is controlled by the primarily choice of spring stiffness and damper coefficient of the damper. The choice of spring constant, damper coefficient gives different aspects. The soft spring and damper setup provide excellent ride comfort by isolation of automobile body from road profile; in the ride comfort point of view, soft spring is better than stiff for the same damper.

B-The active suspension systems

An active control system required external power source or many control actuators that apply forces to the suspension in prescribed manner. These forces can be required to both add and dissipate energy in the suspension.

For this reason, active control strategies were adopted in the field of automobile suspension coming from electrical and mechanical engineering. The real problem of active system is that their energy requirement is large and expensive. This type is a mechatronic system, which include actuators with high bandwidths to damp the vibrations of automobile body and wheels. The performance of the mechatronic suspension can be provided by the components of the actuator via the suitable control law [6].

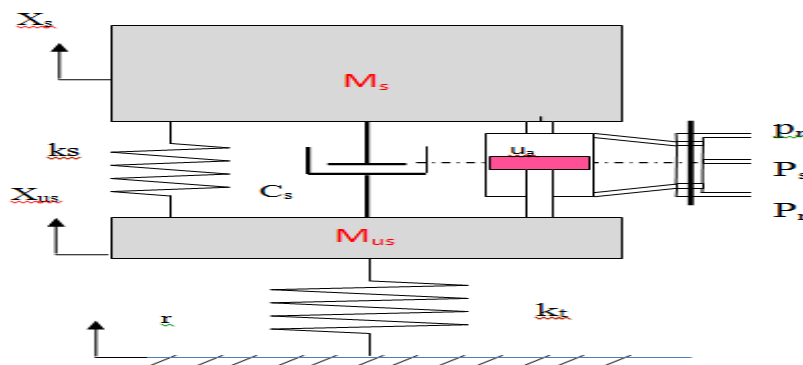

Figure. (7) Schematic of Active suspension system [5]

C-The Semi-Active Suspension System

Let's consider new semi-active hydraulic fluid dampers with on-off behavior. A high value for damping is used when the machine starts or stops, having a low speed (during the acceleration or deceleration). For high speed the value of damping is low. This type of control is very useful only if the dynamics characteristics and the excitation condition are very well known, has the ability of adjusting the damping. The semi-active suspension has less complexity than the active.

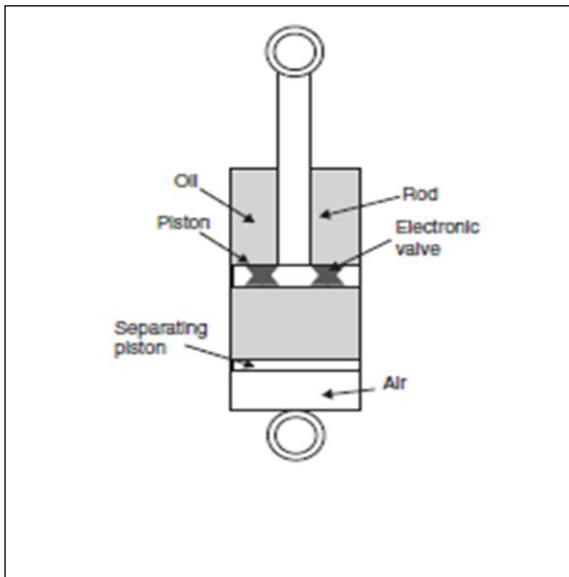

Figure. (8-a) Semi- Active suspension system [7]

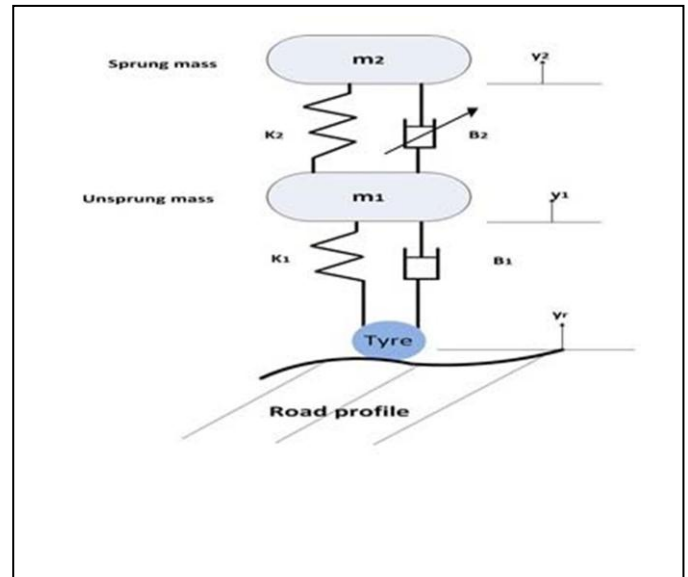

Figure. (8-b) Schematic of Semi- Active suspension system

4. - VEHICLE CRITERIONS

A- Ride Comfort:

Ride comfort criterion is the first objective of automobile suspension system because it is indicating how much automobile is comfortable for passengers, vibration sources which affect ride comfort are classified generally in to two types; on-board sources and road sources, on-board sources considered arising from the rotating components including the engine, the driveline and the wheels, these sources supply the vibration in the frequency region of 25-20000 Hz, and it is called "noise".

The second type of the vibration sources of automobile is the road sources, referring for the road surface roughness and maneuver excitation. The vibration of automobile effect on human body, and it has examined by many investigators, the human body is sensitive to vibrations and it is more sensitive in horizontal directions. In vertical direction the body sensitive is about 4-8 Hz but the sensitive in horizontal direction in range 1-2 Hz (SAE, 1992); with motion for sick person the range is 0.5-0.75 Hz for the emergency vehicle [8].

In order to specify the ride comfort of automobile, the vibration must be recorded in two horizontal directions (i.e. roll, pitch, and yaw). It is preferred to record the acceleration and use the root mean square (RMS) of the recorded acceleration [8.]

$$a_{rms} = \left[1/T \int_0^T a_w^2(t) dt \right]^{1/2} \tag{1}$$



Where T is the time period of suspension vibration and $a_w(t)$ is the frequency weighted vertical acceleration, with frequency weighted and resulting factors are defined in table (1) [8], shows the scale of the suggested discomfort.

Table (1) approximate indications of likely reactions to various magnitudes of overall vibration total values in public transport (ISO2631-1 1997) [8].

Acceleration level	Degree of comfort
Less than 0.315 m/s ²	Not uncomfortable
0.135-0.63 m/s ²	A little uncomfortable
0.5-1 m/s ²	Fairly uncomfortable
0.8-1.6 m/s ²	Uncomfortable
1.25-2.5 m/s ²	Very uncomfortable
Greater than 2 m/s ²	Extremely uncomfortable

And the relation between the acceleration and frequency is illustrated as

$$a_{rms} = \omega_d^2 r \tag{2}$$

$$\omega_d = \sqrt{\frac{a_{rms}}{r}} \tag{3}$$

Where ω_d is the frequency of damping (rad/sec)

And r is the length of the arm between pivot and damper position.

And a is the acceleration (m/s²)

$$\omega_d = 2\pi f_d \tag{4}$$

The measure of ride comfort is the root mean square (RMS) of the vertical acceleration of the automobile body.

B- Road Handling

Road handling is the other important criterion which refers to the relative displacement between mass and the road surface, this displacement due to the force between the tire and the road, which is called the dynamic tire deflection. The force of road handling is calculated by the following equation [6.];-

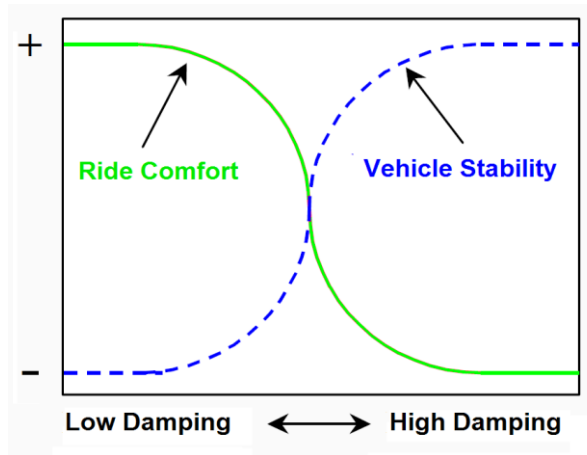

Figure. (9) The compromise present in passive suspension design [6].

$$F_n = (m_1 + m_2)g - [B_1(\dot{y}_1 - \dot{y}_r) + K_1(y_1 - y_r)] \tag{5}$$

Suspension system has an important effect on vehicle dynamics, where it plays a critical role in handling performance and ride comfort of automobiles. The suspension system has two functions the first is to isolate the automobile body from road disturbances, and the other is to maintain a firm contact between road and tires during tracking. The conventional passive suspension comprises of traditional damper or springs. An active suspension system is characterized by employing a suitable kind of suspension force generator using hydraulic pneumatic or electro-magnetic actuators. The semi-active suspension is characterized by the ability of adjusting the damping according to the road profile, in which this ability improves ride comfort and ride stability.

5. - LITERATURE SURVEY

The study of the vibration control strategies of automobile suspension had been treaded by many investigators using different methods for passive, active and semi-active suspension system types of control technique. All the studies in this field pointed to how providing best comfort of riding, and /or stability of riding.

H. Elahi, et.al, [9] this study focused on simple quarter automobile suspension system firstly they used passive suspension control strategy then converted to the semi –active control strategy with automobile suspension system. The study evaluates the damping of automobile suspension system by using Matlab program. This study concluded that the system was stable under lag, lead and lag-lead compensator, also the study showed that the system had very less over shoot (up to 5%) and settling time less than 0.5 second.

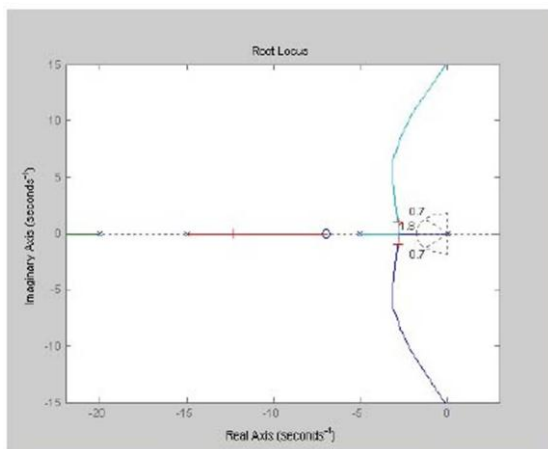

Figure. (10) Root locus of passive suspension [9].

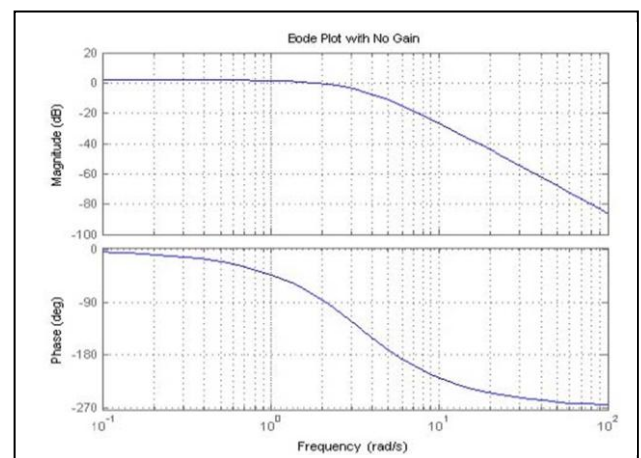

Figure. (11) Bode plot of passive suspension [9].

Kalas Vijay Inamdar, [10] proposed a simulation with numerical method for optimization the acceleration of vehicle suspension system with applying random road excitation. Optimization values of damper parameters were evaluated by using transfer function technique to achieve the simulation of the quarter- automobile model, to generate inputs for good ride comfort and road handling by using good conflicting to compromise between ride comfort and road handling. It was concluded that the numerical method of generating random time series can be efficiency used for simulation of the suspension system considering quarter – automobile model. Also it was found that the damper coefficient for good holding was 10000N.s/m while for passenger ride comfort, the optimum value of the damper coefficient was found 485 N.s/m.

Rijumon K, et.al, [11] focused their study on solving the equation of motion for the mathematical model of passive suspension system and the control strategies that used for semi-active suspension system, with 2DOFquarter automobile model. The solution was performed by using the Simulink program. It was concluded that, the control strategies for semi-active suspension systems using SILS method and the results of simulation showed that, skyhook control had been achieved more reduction of resonant peak of the body mass than of passive suspension and gave good ride comfort. Skyhook and Minimax strategies can be switched during the vehicle was running in proper moment for effectively improving both ride comfort and safety of vehicle.

The study performed by J. Mihai &F. Andronic, [12] focused on semi-active suspension system to remove undesirable oscillations. Different kinds of control system had been developed to obtain adjustable suspension. The viscosity of the damping oil altered using magneto rheological or electro-rheological liquids. This study concluded that, using semi-active systems instead of passive system led to an almost total elimination of the system oscillations, a reduction in the amplitude of the oscillatory phenomenon and a reduction in the settling time, which constitutes a great advantage.

F.L.M Santo et.al, [13] focused on the H- infinity (H_∞) control technique to study a semi-active suspension system, by achieving good compromise between the ride comfort and the road handling criterions. The main goal of this paper was to evaluate the optimal performance for the automobile suspension system, by minimizing the sprung mass acceleration and to ensure suitable road – handling comparing with passive suspension system. The research had been used the quarter – automobile suspension system, after that; the mathematical modeling had been solved by Matlab program. The proposed system had been showed good characteristics, especially when regarding the increasing of vertical acceleration, while showing small degradations regarding the road handling characteristics.

The study by A. Florin, et.al, [14] modeled the ride comfort characteristics of an automobile with passive suspension system. Two degrees of freedom depends on quarter –automobile model. Matlab / Simulink program was used to solve the equations and compared with transfer function and state – space models. The results that obtained from the three methods were very close when using the same parameters of the suspension system.

Mohammad Jawad Aubad, [15] this study presented a new passive suspension system design to develop the isolation performance of the automobile .The design was based on the concept of a variable stiffness mechanism, the main idea was to vary the load transfer ratio by moving of the vertical strut to the automobile body. The technique which used in this study was (LQR), the theoretical and experimental results showed that the variable stiffness proposed suspension system achieved better than the traditional suspension system.

W. Xiao et.al, [16] developed a new method to solve suspension system by Matlab/Simulink program to investigate ride comfort for vehicles. The wheel motor of an electric vehicle mainly affects the smoothness of the automobile mainly in the following aspects: pavement, tire, suspension motor and so on. Through the establishment of the above model, the investigator effectively studied the wheel motor drive electric vehicle ride comfort research. By using Matlab/Simulink, it can easily build different kind of automotive dynamics models, decrease the time in the programming, and also reduce the amount of work. From the simulation of acceleration and power of the automobile body, it can be evaluated the structural performance of the vehicle which was of great significance to the optimization of the vehicle's ride comfort and road handling. Figure (13) shows the Simulink code vehicle body dynamics model.

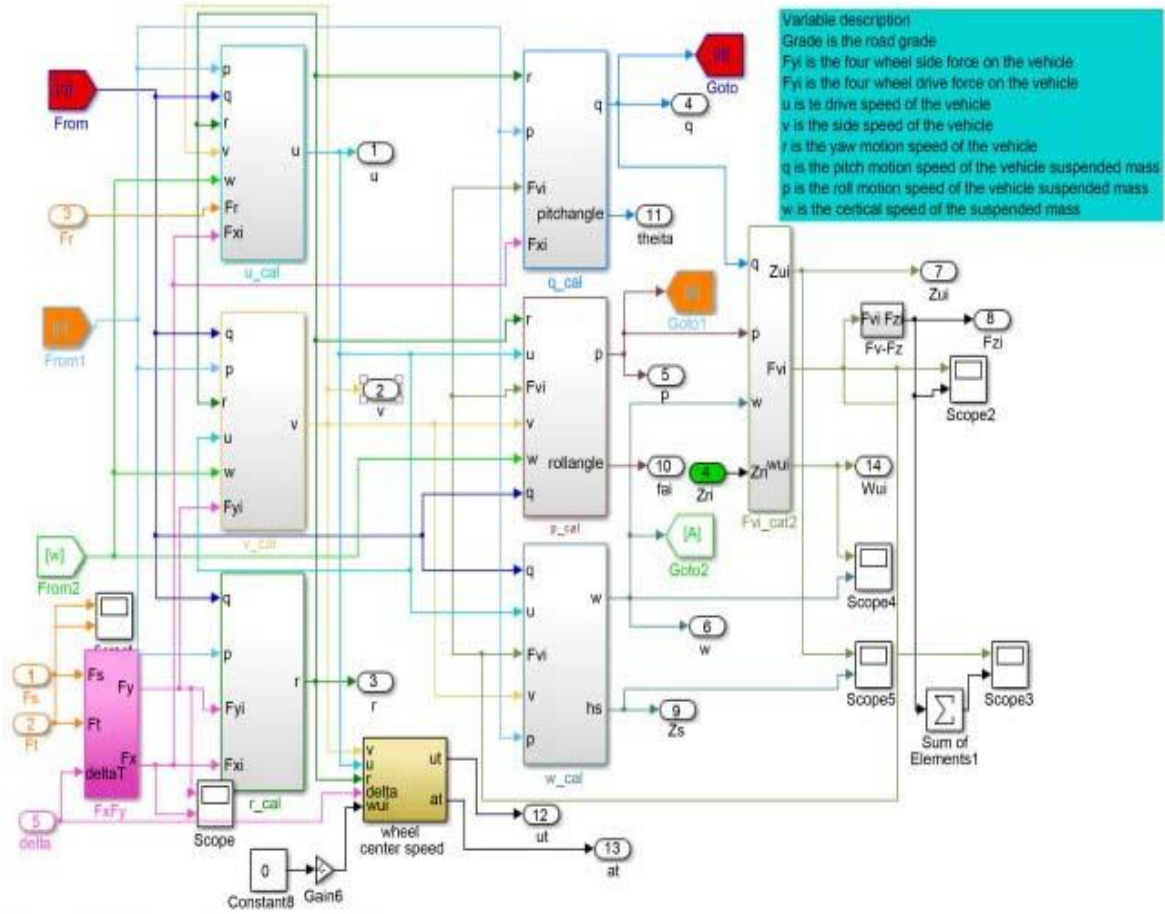

Figure. (12) Simulink code of vehicle body dynamics model [16]

V.S.Dixit and S.C.Borse, [17] presented a study on design and analysis the semi-active suspension system models by using skyhook, ground hook and hybrid control for quarter automobile model. Generally there were three main objectives from using suspension system of automobile; improving ride comfort, improving road handling and suspension working space. Simulation was performed for different road conditions such as random road excitation, road bump excitation, step input.

Ameen Ahmed Nassar,[18] the aim of this study was to develop a new Matlab graphical user interface GUI to solve a vibration equations of quarter automobile suspension system, and another aim of this study was to check the ability of Matlab GUI modeling and solving the quarter automobile suspension system. The paper concluded that GUI was very benefit for design and analysis for quarter car suspension systems because of its efficiency and simplicity of this approach. Figure (14) shows the results of this study.

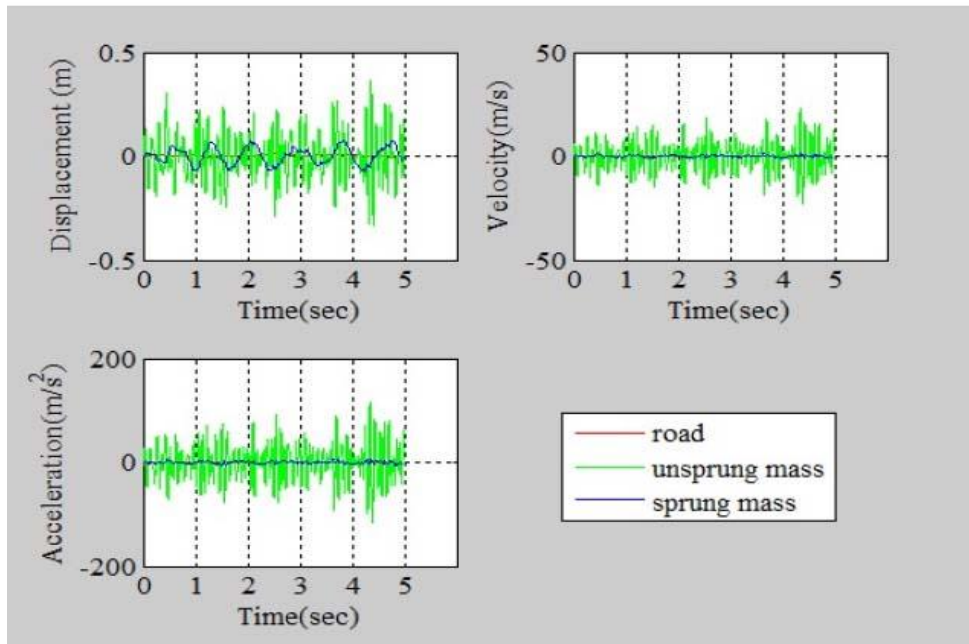

Figure. (13) Response of suspension system [18]

P. Sharma, et.al [19] focused on the solution of ordinary differential equation for a quarter – automobile model as two degrees of freedom system. The mathematical modeling had been solved by Matlab program to determine the displacement of sprung mass and unsprung mass. This also had been given the velocities for suspension and travel response when the automobile pass over bump with damping ratio of 0.078. This study concluded that the amplitude of acceleration was found to be 1.7m/s^2 and the overshoot was about 70%. This result of acceleration of the sprung mass was very high and undesirable for the automobile; but unsprung mass, the maximum overshoot was 30% and the acceleration was reduced from 4 to 0.7 m/s^2 which was undesirable.

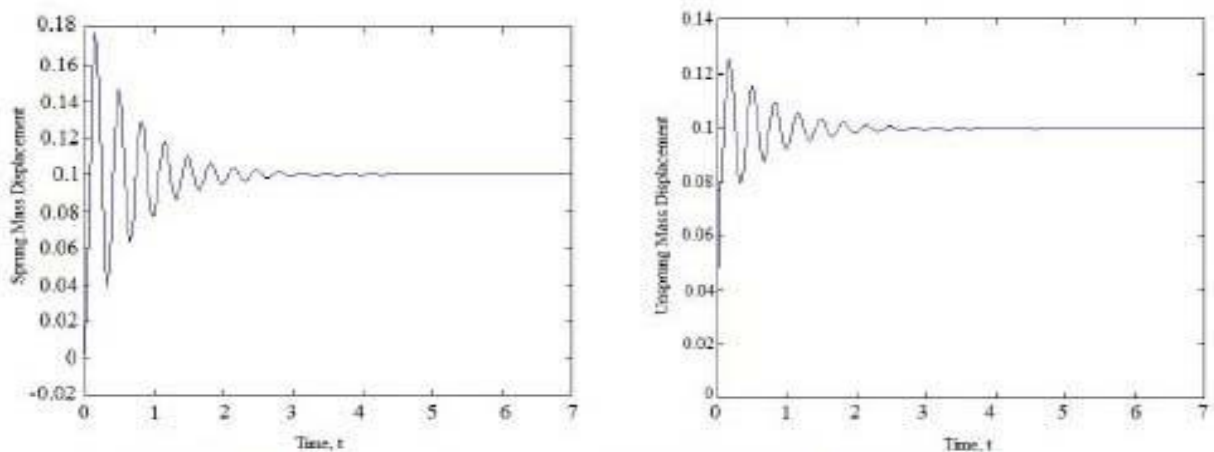

Figure. (14-a) Response of sprung mass of suspension system [19]

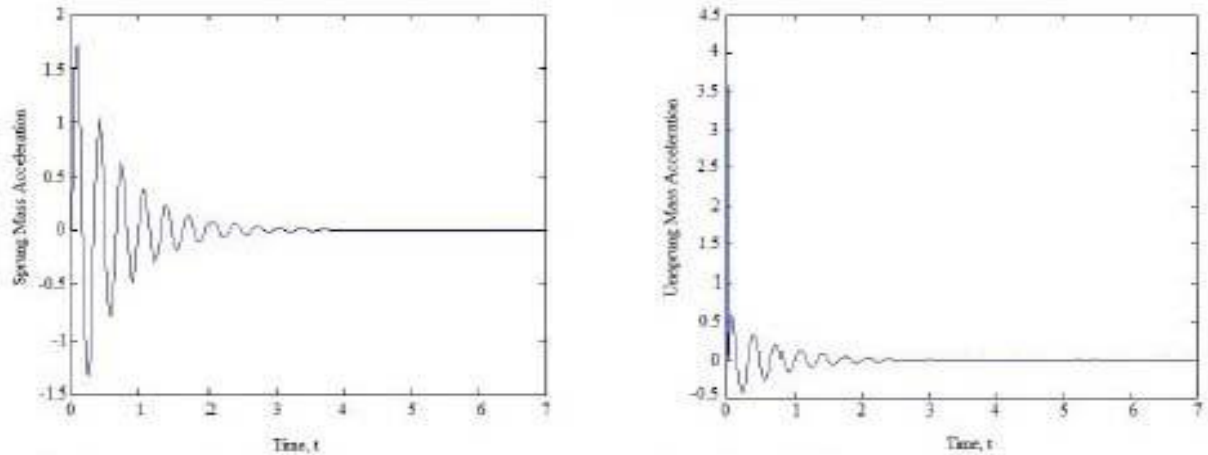

Figure. (14-b) Response of unsprung mass of suspension system [19]

Qi Zhou, [20] presented a new technique in automobile suspension system. New algorithm and pavement feedback, combined with PID controller which improves the performance of the suspension system. This study carried out on a quarter automobile model. Simulink program was used to simulate the model. It was concluded that the PID controller reduced the vibration amplitude, but; there was increasing in the acceleration. Also it was found that the pavement feedback control technique had a good performance with white noise input and was not suitable with the other types of inputs.

Table (1) shows different road level [20].

Road Level	$G_q(n_0) / (10^{-6} m^3)$	$\sigma_q / (10^{-3} m)$
	$(n_0 = 0.1 m^{-1})$	$0.01 m^{-1} < n < 2.83 m^{-1}$
	Geometric Average	Geometric Average
A	16	3.81
B	64	7.61
C	256	15.23
D	1024	30.45
E	4096	60.90
F	16384	121.80
G	65536	243.61
H	262144	487.22

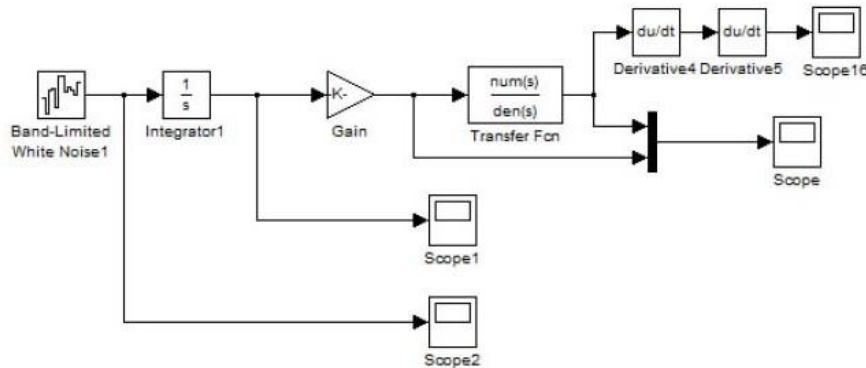

Figure. (15) Simulink program of passive suspension system with white noise input [20]

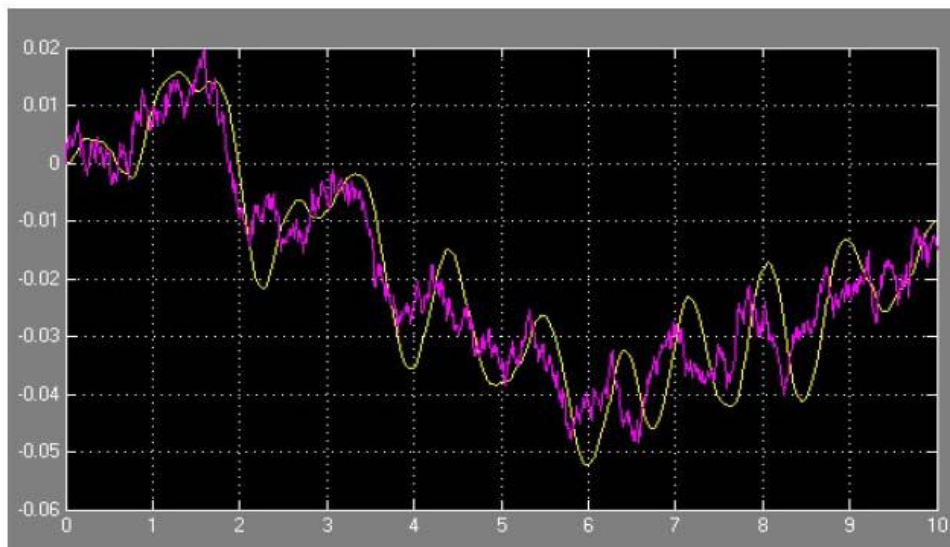

Figure. (16) The passive suspension system output displacement time response with the input of white noise signal [20]

M. Ibrahim, et.al, [21] their study focused on an active suspension system by using two control methodologies which were Proportional Integral Derivative (PID) and Intelligent Fuzzy Logic control (IFL). They had been compared their results with those of passive control for quarter automobile suspension system. Matlab /Simulink program had been used to implement the two techniques mentioned above and the results had been showed that the PID controller improved the tracking of the system and had the ability of eliminating all vibrations during the time period, whereas the FLC technique tracked the input signal through the half cycle and out controlled for the rest of the time period.

Vivek Kumar Maurya and Narinder Singh Bhangal, [22] their study focused on two methodologies PID and LQR controller, the simulation had done by Simulink/ Matlab program, according to this simulation, both PID and LQR controller were successfully designed by Simulink/ Matlab, both controller were very effectively as compared to passive suspension system, but; it was found that the LQR controller was better than PID controller as well as passive suspension system.

Senthilkumar and Mouleeswaran, [23] focused on quarter automobile suspension system by using proportional- integral- derivative (PID) controller to get good compromise between ride comfort and holding criterions. Designing of PID controller according to Zeigler and Nichols suggested rates to determine the integral and derivative time constants (T_i & T_d) and proportional gain (K_p) were calculate from critical gain (k_r) from Bode Plot and the time period at critical gain which was called critical period P_{cr} . Two kinds of inputs that used in this study; sinusoidal and random inputs; random input depended on power spectral density and classification of roughness of road surfaces according to International standards.

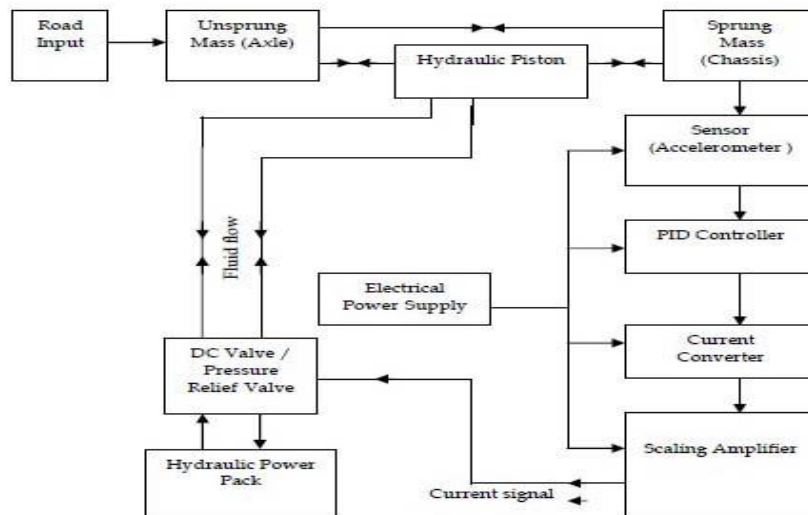

Figure. (17) Block diagram of control system strategy that was proposed by Ref. [23]

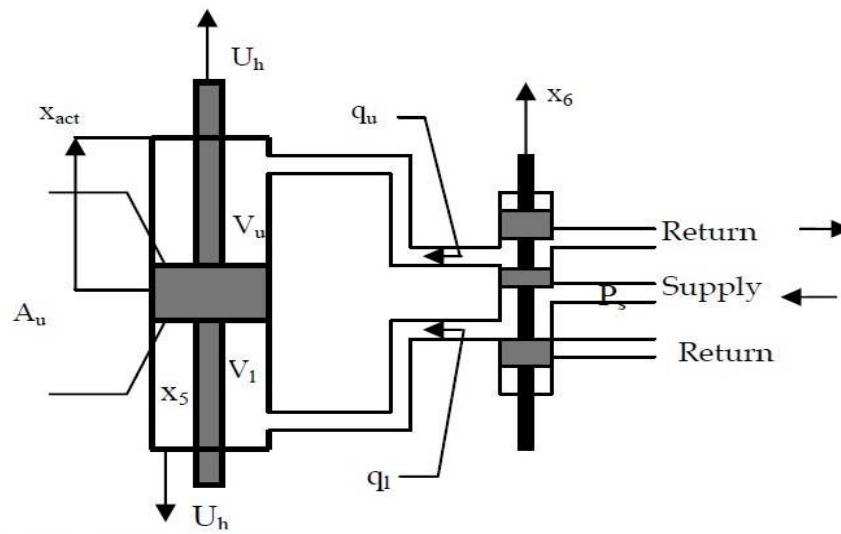

Figure. (18) Active suspension system with PID controller that was proposed by Ref. [23]

Siau Ping Tee, et al, [24] performed a mathematical model for two – degrees of freedom passive suspension system, as an open loop to determine the transfer function by investigating the closed loop with PID controller, using Matlab program to design the parameters of the PID controller which involved proportional gain (K_p), integral gain (K_i) and derivative gain (K_d) until reaching to minimum overshoot and minimum steady state error. The study concluded that, a PID controller with the values $K_p = 1.35$, $K_i = 0.021$, $K_d = 0.0022$ was successful design to get best performance of a system for passive quarter automobile suspension system subjected to various road disturbances.

G. K. Sinha and U. Prasad,[25] focused their study on quarter –automobile model to investigate the response of suspension system and to improve the vehicle handling, ride comfort for large or heavy automobile. The improvement of performance was done by using many controllers such as PI, PID and H_∞ , based on step input signal. The study concluded that for passive suspension system, the overshoot observed as 0.08m from 0.1 m and settling time is 35 sec, which means that the passengers felt low oscillation for long time, but when the PI controller was used, the overshoot reduced to 0.0058m and settling time to 6 sec, while when the PID controller was used, the overshoot reduced to 0.0039 and settling time to 2 sec and when the H_∞ was used, a better performance of the stability of the vehicle can be presented.

M. Akpakavi, [26] investigated the quarter automobile model for large or heavy vehicles. This paper investigated the response of suspension system when using passive strategy, and then investigated the response when the P, PI and PID controllers used for the same parameters of the quarter – automobile model. The study concluded that for step input, the overshoot was 0.08 m of 0.1 m, the settling time was 38 seconds that is the people whom sitting felt small oscillation for long time, thus the P, PI and PID controllers were used to improve the response.

Hassan Ahmed Metered, [27] focused his study on magneto rheological (MR) damper, by controlling voltage signal which adjusted the properties of this damper. Semi- active suspension system had advantages of both active and passive suspensions. The damping force was evaluated from both simulation and experimental data. The study concluded that the simulation results gave a good dynamic behavior which led to a good ride comfort.

[Hassan, *et al.*, 8(10): October, 2019]
ICTM Value: 3.00

The study given by Uchenna. HDiala, Glorra.N.Ezeh, [28] concerned with the semi-active control for a magneto rheological (MR) damper. The simulation was done by using Matlab/Simulink program with proportional – integral – controller to examine the effect of a cubic viscous damping parameter on the isolation of system vibration. The methodology of controller that used with this study was PI controller which regulating to obtain the desired nonlinear viscous damping factor with semi-active (MR damper). "An increase in the nonlinear viscous damping characteristics parameter $\zeta=0, 0.2, 0.4$ and 0.7 maintain the transmissibility at frequency range greater than and less than resonant frequency".

Ali Fa'az Hasan, [29] investigated a semi-active tuned damper which depended on the varying orifice area, the operation of opening and closing the orifice leads to varying the effective area which the damping oil flowing through it. The change in orifice area made the damping factor to be variable; therefore the damping force will be varied too. The neural network system identification (NNSI) was used to describe the operation of the components of the suspension system and to test the performance of this damper to get the results. The results showed that this controller with a semi-active tuned damper decreased the root mean square (RMS) of the acceleration from 22m/s^2 to 0.422m/s^2 at resonance frequency. Figure (19) shows the experimental work which was done by the researcher.

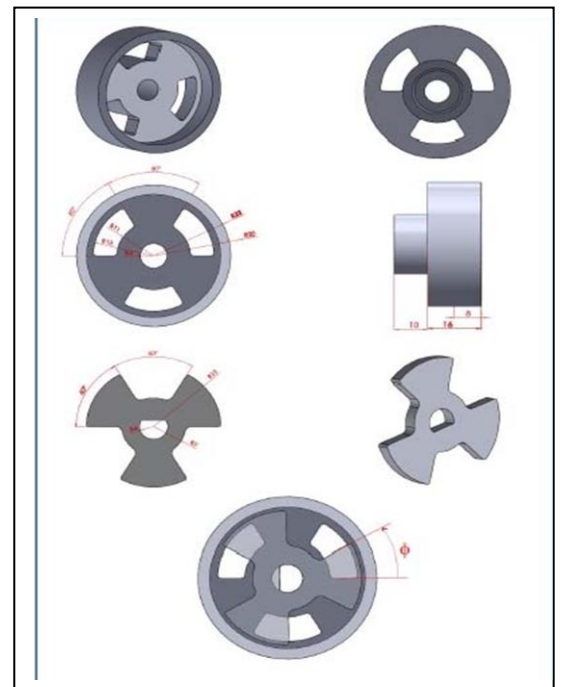
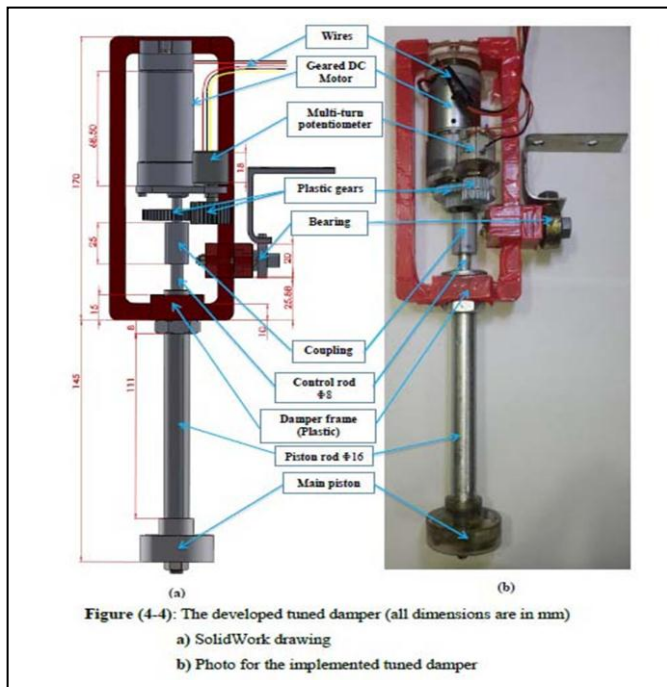

Figure. (19) Experimental work for proposed damper by [29].

6. - CONCLUSIONS

- It can be concluded that the vibration control of automobile suspension system may be achieved by the three main types of control which included passive, active and semi-active controlling, also can be using different types of control methodologies such as H infinity, PID, LQR and Fuzzy controllers to improve the performance of automobile suspension system.
- The aims of all researches in the field of vibration control of suspension system are to control the vibration which is introduced due to external disturbance during the vehicle passes over terrain and to absorb this vibration and to maintain the parts of the vehicle from fatigue and provide suitable ride comfort and good road handling for the vehicle.
- From the previous studies, it was seen that the semi-active system was better than the passive system and the active system was better of all but when the active system was used this required high external power to operate the controller so as to give suitable characteristics of the control system.
- From this study it can be concluded that any automobile suspension system may coincide with a certain technique of control that can make the automobile suspension system work in an optimal situation according to ride comfort and road handling criteria.
- Also it can be concluded that using the Simulink program to solve the equation of motion of a quarter automobile suspension system is very important due to the complexity of solving by traditional methods which were used to solve these cases.
- In any suspension control strategy must be achieved a good compromise between ride comfort for the passenger and road stability for the vehicle.
- This study concluded that using PID, LQR, H infinity and Fuzzy controller which had been improved the performance of the suspension system strongly, especially, the improvement in the time of steady state response whereas by using PID and Fuzzy controllers led to decrease the time of steady state response and reduced the maximum overshoot.

REFERENCES

- [1] Robert P. Tata, J.C. (2007): "Automotive suspension system", Continuing Education and Development, Inc. 2012.
- [2] John C. Dixon "The Shock Absorber Handbook", John Wiley & sons, Ltd., 2007.
- [3] Shijil P, Albin Vargheese, Aswin Devasia, Christin Joseph, Josin Jacob, "Design and analysis of suspension system for an all-terrain vehicle", International Journal of Scientific & Engineering Research, Volume 7, Issue 3, March-2016.
- [4] Shrikant S Dodamani, C Suresh, Nagaraj D, "Design and Fatigue Analysis of Mac Pherson Strut Assembly Coil Spring", International Journal of Innovative Research in Science Engineering and Technology, Vol.5, Issue 7, July 2016.
- [5] Ernesto Rocca & Francesco Timpone, "Analysis of multi-link suspension characteristics due to the road length variation", Proceedings of the world congress on Engineering 2016 Vol. II, June 29-July 1, 2016, London .U.K.
- [6] Shahriar Sarami, "Development and Evaluation of a semi-active suspension system for suspension tractors", M.Sc. Thesis, Berlin, 2009.
- [7] S. M. Savares "Semi-active suspension control design for vehicles", British Library Cataloguing in Publication Data, Published by Elsevier Ltd, 2010.
- [8] Yka Marjanen, "Validation and improvement of the ISO2631-1(1997) standard method for evaluation of discomfort from whole-body vibration in a multi-axis environmental", PhD. thesis, Loughborough University, 2010.
- [9] Hassan Elahi, Asif Isar, M. Zubair Khan and Shamraiz Ahmed, "Robust Vehicle Suspension System by Converting Active & Passive Control of a Vehicle to Semi-Active control System Analytically", Journal of Automation and Control Engineering Vol.4, No.4, August 2016.
- [10] Kailas Vijay Inamdar, "Vehicle Suspension Optimization for Stochastic inputs", M.Sc. Thesis, the University of Texas at Arlington, 2011.

- [11] Rijumon K, Murtaza M A, Ajith Krishnan, "A comparison between passive & Semi Active Suspension System", International journal of Innovative research in Science, Engineering and Technology, vol. 2 Issue 6, June 2013.
- [12] M.F.Antronic, "Behavior of a semi-active suspension system versus a passive suspension system on an uneven road surface", ISSN1392-1207, MECHANIKA.2014volume 20(1):64-69.
- [13] Fabio Luis Marques dos Santos, Luiz Carlos Sandoval Goes, Alberto Luiz Serpa, "Semi- Active Suspension control with one measurement sensor using H_{∞} Technique", 9th Brazilian Conference on Dynamics, control and their Applications, June 07-11, 2010.
- [14] Andronic Florin, Manolache-Rusu Ioan- Cozmin, Patuleanu Liliana, "Passive Suspension Modeling using Matlab, Quarter Car Model, in put Signal Step Type" TEHNOMUS-New Technologies and products in machine Manufacturing Technologies.
- [15] Mohammed Jawad Aubad "Design and modeling of an automobile suspension system", PhD. Thesis, University of Bagdad, Iraq, 2017.
- [16] Wenwen Xiao, Feihu Xuan, huanghuang zhang, "Research on ride comfort model of wheel motor driving vehicle based on Matlab/ Simulink", Scientific Research publishing, ISSN print: 1947-3931, China, 2017.
- [17] V. S. Dixit, S. C. Borse "Semi –Active Suspension System Design for Quarter Car Model and its analysis with Passive Suspension Model", International Journal of Engineering Sciences & Research Technology, 2017.
- [18] Ameen Ahmed Nassar, "Graphical user Interface (GUI) for vibration Analysis of Quarter car suspension system using Random and step- function road profiles", Universal Journal of Mechanical Engineering 3(3): 83-93, University of Basrah, Iraq,2015.
- [19] Pankaj Sharma, Nittin Saluja, Dimple Saini and Parveen Saini, "Analysis of Automobile Passive Suspension system with Matlab Program Generation", International Journal of Advancements in Technology, Vol.4, no.2 pp.115-119, 2013.
- [20] Qi Zhou "Research and Simulation on New Active Suspension Control System", MSc. Thesis, Lehigh University, 2013.
- [21] Muhammed Ibrahim Faruk, Amir Bature, Suleeiman Babani, Najib Dankadai, "Conventional and Intelligent Controller for Quarter Car Suspension System", International Journal of Technical Research and Applications, e-ISSN: 2320-8163, vol.2, special Issue 1(July-Aug2014), pp., 24-27.
- [22] Vivek Kumar Maurya and Narinder Singh Bhangal, "Optimal control of vehicle active suspension system", Journal of Automation and Control Engineering Vol.6, No.1, June 2018, India.
- [23] Senthilkumar Mouleeswaran,"Design and development of PID controller –based active suspension system for automobile"www.intechopen, 2012.
- [24] Siau Ping Tee, Mariam Md Ghazaly, Aliza Che Amran, and Irma Wani Jamaludin, "Experimental Investigation of A Passive Quarter Car Suspension System ", ARPN Journal of Engineering and Applied Sciences, ISSN 1819-6608, vol.13, No.4, February 2018.
- [25] G. K. Sinha & Prof.(DR.) U. Prasad, "Vibration Control of Car Suspension System using Different Controllers" International Conference on Emerging Trends in Engineering, Technology, Science and Management,ISBN:978-93-86171-38-2,India,2017.
- [26] M. Akpakpavi, "Modeling and Control of a Car Suspension System Using P,PI,PID GA-PID and Auto-Tuned PID Controller in Matlab/ Simulink" Journal of Multidisciplinry Engineering Science Studies (JMESS) ISSN:2458-925X,vol.3,Issue 3,March-2017.
- [27] Hassan Ahmed Metered, "Modeling and control of magneto rheological damper for vehicles suspension systems", PhD. Thesis, University of Manchester, 2010.
- [28] Uchenna. H. Diala and Gloria. N. Ezeh, "Nonlinear damping for vibration Isolation and Control using semi- Active methods", SAVAP International, 2012.
- [29] A. F. Hassan, "Theoretical and Experimental Study of Controlling Vibration of a single Degree of Freedom System using Tuned Damper", M.Sc. Thesis, University of technology, Iraq, 2015.